

# MANUAL

## Digital Battery - Drive BAMOBIL – D3-IM for EC - Servomotoren



Edition / Version

07/2013 V 7

## 1 Contents

2	Basic information .....	3
2.1	History .....	3
2.2	Further products .....	3
2.3	Engineering instructions (MANUAL) .....	3
2.4	Validity .....	4
2.5	Designations and symbols .....	4
2.6	General information .....	5
2.7	Applications .....	6
2.8	Build .....	7
2.9	Safety information.....	8
2.10	Commissioning .....	10
2.11	Safety advice .....	11
2.12	Intended applications .....	12
2.13	Regulations and guidelines .....	13
2.14	Risks .....	14
2.15	Technical data .....	15
3	Mechanical installation .....	19
3.1	Important instruction .....	19
3.2	Dimensions BAMOBIL D3-IM .....	20
3.3	Power connections .....	21
3.4	Additional cooler .....	22
4	Electrical installation .....	24
4.1	Important advices .....	24
4.2	Circuit diagram .....	25
4.3	Connection diagram .....	27
4.4	EMV advice .....	28
4.5	Connectors X1 ,X7 .....	30
4.6	Battery connection .....	31
4.7	Motor power connection .....	34
4.8	Control signals .....	35
4.9	Safety input RFE (Rotating field enable) .....	36
4.10	Digital logic output (open-emitter) .....	37
4.11	Serial Interface RS 232 .....	39
4.12	CAN BUS .....	40
4.13	Resolver connection .....	41
4.14	Encoder TTL connection .....	42
4.15	SIN COS 1Vss connection.....	44

# Basic information

---

- 4.16 Display - State ..... 46
- 4.17 Error displays ..... 47
- 4.18 Warning signals ..... 48
- 4.19 Measured data ..... 49
- 4.20 Output stage temperature ..... 50
- 5 Warranty ..... 51
  - 5.1 Warranty ..... 51



## 2 Basic information

### 2.1 History

Version	Modification	Date
07/2013-V3	Changed graphic auxiliary voltage connection Appendix A - Notes accounts	20.11.2013
07/2013-V4	Dimension / Bolt size	27.03.2014
07/2013-V5	Chapter Battery connection Additional risk of fire by arc	07.07.204
07/2013-V6	Error list / Alarms / Indicators (Chapter 4.16 / 4.17 etc.)	24.10.2014
07/2013-V7	Fax-no. / version each page / Dimensions	28.11.2016

### 2.2 Further products

Digital servo-amplifiers for small power values	>>>		DS205, DS403
Analog three-phase servo-amplifiers TVD3, TVD6, AS	>>>		Series
Analog dc servo-amplifiers TV3, TV6, TVQ6	>>>		Series
Thyristor current converters 1Q, 4Q, Servo	>>>		Series Classic 200W to 800kW
DC and ac servo-amplifiers for battery operation A2, A3, D3			Series BAMO
Analog and digital			Series BAMOBIL Series BAMOCAR

### 2.3 Engineering instructions (MANUAL)

- |    |        |                 |                                    |
|----|--------|-----------------|------------------------------------|
| 1. | MANUAL | BAMOBIL – D3-IM | Hardware                           |
| 2. | MANUAL | NDrive2         | Software                           |
| 3. | MANUAL | DS, DPC         | Commissioning –<br>Troubleshooting |

**Use all three MANUALs for the engineering, the installation, and the commissioning!**

CD (DOKU-SOFT) supplied with the delivery of the units.



The hardware MANUAL comprises warning and safety advices, explanations of standards, mechanical and electrical installation advices.

The MANUAL must be available for all persons who are concerned with the unit.

## 2.4 Validity

Hardware-Stand:	
Firmware-Stand:	

## 2.5 Designations and symbols

Unit:	BAMOBIL D3-IM
User:	Manufactures or operators of vehicles, machines or installations in the industrial sector (B2B, secondary environment)
Dealer:	<b>Stegmaier-Haupt GmbH</b>
	<b>Caution – Danger to life! High voltage</b>
	<b>Warning! Important</b>
	<b>Dangerous electric fields</b>

### Delivery scope:

Device BAMOBIL D3-IM , documentation, CD DOKU-SOFT in the packaging of the delivered goods.

Not included in the delivery scope:

Accessory equipment, connectors, and cable screw glands

35-pole connector type: Tyco 776164-1

14-pole type: Tyco 776273-1

Cable screw gland M25x1.5

## 2.6 General information

The digital 3-phase current servo amplifiers **BAMOBIL** as component in combination with the motor provide a 4-quadrant drive which can be used in both rotation directions for drive operations and brake operations with energy feed-back.

According to the installed parameter components the amplifiers are suitable for EC synchronous motors, ac asynchronous motors, or dc motors.

The individual drive versions have different advantages and disadvantages:

The **EC drive** (synchronous motors) has the highest efficiency and performance per weight and volume and provide a drive solution free of maintenance and with a wide dynamic control range. However, the high braking torque in case of motor short-circuits is a disadvantage and it is also difficult to control the field weakening range.

From the electrical view, the EC synchronous motor (brushless dc motor) is a synchronous motor with a permanent magnet rotor and a three-phase current stator.

The physical characteristics correspond to those of dc motors, i.e., the current is proportional to the torque and the voltage is proportional to the speed. The speed is steadily controlled up to the current limit (max. torque). In case of an overload the speed drops and the current remains constant.

The speed/torque characteristic is rectangular.

Current, speed, and position are precisely measured. The field frequency is not controllable, it is automatically adjusted.

The motor voltages and the motor currents are sinusoidal.

The **ac drive** (asynchronous motors) has the widest speed range due to the single field weakening and there is no braking torque in case of a motor circuit. The unit size and the worse efficiency.

The rotating field frequency can be controlled in due consideration of the motor specific parameters (field-based control). The motor voltages and motor currents are sinusoidal.

The active current and the magnetising current must be supplied by the controller.

With both 3-phase current systems there will be no motor movement neither when the rotating field is switched off nor in case of an output stage damage. Most of the heat losses are generated in the motor stator.

The **dc drive** (dc motor) has the most uniform running and a wide control range. It is possible to provide an emergency operation by directly connecting the battery voltage. The carbon brushes and the heat development in the armature are disadvantages. The drive may run at high speed in case of an output stage damage.

The current is proportional to the torque and the voltage is proportional to the speed.

Current, speed, and position are precisely measured. The speed is steadily controlled up to the current limit (max. torque). In case of an overload the speed drops and the current remains constant. The speed/torque characteristic is rectangular.

Field weakening might occur with separately excited motors.

The **Bamobil D3-IM** can be used as position amplifier or torque or speed amplifier.

The speed actual value is generated in the encoder unit (resolver or others) or internally generated (without sensors). It is necessary to provide an encoder system for wide control ranges and high control dynamics.

## 2.7 Applications

Application in all kinds of vehicles, machines, and installations for all types of industrial use with a drive power of 18 kW, especially as 4Q-servo-drive for

- highly dynamic acceleration and braking cycles
- a wide control range
- a high efficiency
- small motor dimensions
- a uniform, accurate and smooth running

To be used for the speed or torque control or combined speed/torque control incorporated within or independent of position control loops. For drives with constant speed as in conveyors, spindle drives, pumps, transversal or longitudinal pitch drives, synchronous multiple motor drives. Synchro-servo-drives are more compact than other electric drives

### Particularly suitable for:

Battery-driven vehicles such as electric vehicles and boats, forklifts, transportation systems as well as battery-supplied machines and installations such as assembly machines, metal working machines, food processing machines, robots and handling systems, conveyors, stone working machines, and for many other battery-supplied industrial applications.

### EC/AC motor features

- protection rating IP65
- compact
- suitable for rough surroundings
- suitable for high dynamic overload
- free of maintenance

### Note:

Brushless drives are used where braking operations are predominant, e.g. with winding machines, lifts, great centrifugal masses



The braking energy is fed to the battery.

For dc mains the braking energy must be absorbed in the mains without the voltage exceeding the permissible value. If this cannot be guaranteed, a ballast circuitry must be used.

**Note: Pay particular attention when used with laboratory power supplies.**

### For non-earthed systems (vehicles, IT networks)

the isolation between parts accessible to touching and high voltages must be guaranteed and monitored by using independent isolation monitors.

## 2.8 Build

- Compact devices according to the VDE, DIN and EU regulations
- Splash-proof housing IP65
- Standard digital control electronics
- Power electronics for 100 A to 450 A
- Independent 12 V= to 24 V= chopper power supply unit for the auxiliary voltages
- Nominal power input range of 12 to 120V=
- Additional cooling unit for air or water cooling

### Galvanic isolation

- between the housing and all electric parts
- between the auxiliary voltage connection and the power section and the control electronics
- between the power section and the control electronics
- between the control electronics and the logic inputs/logic outputs

The distance of air gaps and leakage paths adhere to the EU standards.

### Components

- FET power semi-conductors, comfortably over-dimensioned
- Only components customary in trade and industrially standardised are used
- SMD equipment
- 7-segment LED displays

### Characteristics

- Battery-powered or dc connection 12 V= to 120 V=
- Independent auxiliary voltage connection 12 V= to 24 V=
- Digital interfaces RS232, CAN BUS (further option)
- 2 analogue inputs, programmable differential inputs
- 4 digital inputs/outputs, programmable, optically de-coupled
- Linear command value ramp, non-linear (s-function)
- Logic for enable and the output stage switch
- BTB ready for operation, solid state relay contact
- Position, speed and torque control
- Resolver or incremental encoder TTL, SINCOS 1 Vss, rotor position + bl tachometer
- Static and dynamic current limiting
- Uniform, completely digital control unit
- Protective switch-off from the motor in case of over-voltage, under-voltage, or over-temperature
- Intrinsically safe and short-circuit proof power section
- Processor-independent hardware switch-off in case of short-circuits, circuits to earth, over-voltage and over-temperature at the output stage



### 2.9 Safety information

**In principle electronic equipment is not fault proof!**

## Caution – High voltage

**DC 200 V =**

**Shock hazard!**

**Danger to life!**

**Discharge time of the bus circuit 4 min!**



Before installation or commissioning begins, this manual must be thoroughly read and understood by the skilled technical staff involved. It must be ensured that the documentation (manuals) and thus, the knowledge of the unit and especially the safety advices must be available for all persons who are concerned with the unit

If any uncertainty arises or if any function is not or not sufficiently described in the documentation, the manufacturer or dealer should be contacted.

Any incorrect installation/connection may damage the device!

Any incorrect programming may cause dangerous movements!

#### **Intended applications:**

The devices of the BAMOBIL x series are power electric parts used for regulating energy flow.

They are designed as components to control EC synchronous motors, ac asynchronous motors, or dc motors in vehicles, machines, or installations for industrial applications.

For applications in residential areas additional EMC measures are necessary.

Any other type of application must be approved by the manufacturer.

The user must draw up a hazard analysis for his end product.

Protection rating IP65.

**Note:** Energy feedback during braking operation.

Pay particular attention when used with laboratory power supplies or dc power supplies.

**Operation only allowed when the device is closed!**

**The control and power connections may be voltage-carrying without the axis operating!**

**The discharge time of the bus circuit is superior to 4 min!**

**Measure the voltage before any disassembly!**



**The user must draw up a hazard analysis for his machine, vehicle, or installation.**

**The user must ensure that in the event of:**

- device failure
- incorrect operation,
- loss of regulation or control

the axis will be safely de-activated.



It must also be ensured that the vehicles, machines, equipment, or vehicles are fitted with device independent monitoring and safety features.

Appropriate measures must be taken so that man as well as property are not exposed to danger due to incorrect or improper movements at any time!

During operation the device must be closed and the safety systems must be enabled.

When the device is open and/or the safety systems are de-activated, it must be ensured by the operator that only skilled and suitably trained personnel has access to the units.



**Assembly**

- should only be carried out when all voltages have been removed and the units are secured
- should only be carried out by suitably trained personnel

**Installation**

- should only be carried out when all voltages have been removed and the units are secured
- should only be carried out by suitably trained personnel for electricians
- should only be carried out in accordance with health and safety guidelines

**Adjustments and programming**

- should only be carried out by suitably trained personnel with knowledge in electronic drives and their software
- should only be carried out in accordance with the programming advice
- should only be carried out in accordance with health and safety guidelines

## 2.10 Commissioning

The battery servo amplifiers BAMOBIL D3xx are components of the electronic drive technology. They are functional only in connection with an electrical consumer (e.g. a motor). Their use is limited for industrial, commercial applications.

When mounting the units into vehicles, machines, and installations the proper operation of the units may not be started until it is ensured that the machine, the installation, or the vehicle comply with the regulations of the EC machinery directive 2006/42/E and the EMC guideline 2004/108/EG.

On the installation and test conditions described in the chapter 'EMV advices' it is adhered to the EC guideline 2004/108/EG including the EMC standards EN61000-2 and EN61000-4.

For applications in residential areas additional EMC measures are necessary.

A manufacturer's declaration can be requested.

The manufacturer of the machine or installation is responsible for observing the threshold values demanded by the EMC laws.

## 2.11 Safety advice

### **Machinery directive**

The manufacturer of the machine or installation must draw up a hazard analysis for his product. He must make sure that any unpredictable movements do not cause damage neither to persons nor to property.

### **Skilled personnel**

#### **Hardware**

The skilled qualified personnel must feature a training and instruction for an assignment in the field of electronic drive engineering. They must have knowledge of the standards and accident prevention regulations for drive engineering applications and they must be familiar with this field of activity. Eventually occurring dangerous situations are realized.

The local regulations (IEC, VDE, VGB) are known to the qualified personnel and they are observed during the works.

#### **Software**

The skilled qualified personnel for handling the software must be trained to safely program the units in the machines and installations. Incorrect parameter settings may cause improper and impermissible movements. Any parameter settings have to be checked for faulty operation. Acceptance tests must be thoroughly carried out according the four-eyes principle

### **Working environment**

Incorrect handling of the units may cause damage to persons or property.

When operating the units the switch cabinet must be closed and the safety systems must be enabled! Exceptions to this are the first commissioning or if switch cabinet repair works have to be carried out by the skilled qualified personnel.

Any unit covers must not be removed!

Disconnect the power supply prior to any works on electric connections and safeguard the switch cabinet against switching-on.

Any voltages and residual voltages (buffer circuit) must be measured prior to any works on the unit. Max. permissible voltage <42 V.

High temperatures (> 70 °C) may arise.

The working environment may be dangerous for persons having electronic medical aids or appliances (e.g. cardiac pacemakers). Sufficient distance to these electrical parts must be observed.

### **Exposure**

During transport and storage the prescribed and specified climatic conditions must be adhered to. The units must not be mechanically damaged. Warped and bent housing parts may influence or damage the isolation distances. Damaged units must never be installed!

The units comprise parts which may be damaged by electrostatic discharge. The general recommendations for handling electrostatic devices must be observed. Special attention should be paid to strongly isolating plastic films and synthetic fiber.

For the operation it must be ensured that the environmental conditions in the switch cabinet are adhered to. This applies in particular to the impermissible condensation on the units.

## 2.12 Intended applications

The devices are designed as components to control EC synchronous motors, ac asynchronous motors, or dc motors in vehicles, machines, or installations.

Any other type of application must be approved by the manufacturer.

Protection rating IP65.

Industrial site of operation only. For applications in residential areas additional EMC measures are necessary.

The user must draw up a hazard analysis for his end product.

Only allowed to be connected to batteries with a battery-side limitation of the charging current. For voltages >60 V an isolation monitoring unit must be installed.

The user must ensure that the complete control wiring complies with the standards.

It must be paid attention to the equipotential bonding for components which are connected to the unit and which do not have isolated inputs and outputs (equalizing connection GND). The equalizing currents may destroy components and parts.

When measuring the isolation the units must be disconnected or the power connections must be bridged together and the control connections must be bridged together.

Non-observance will cause damage to the semi-conductors in the unit.

Repeating circuits to earth and short circuits the values of which are all below the response threshold for short circuits may cause damage to the output stages (conditionally short-circuit proof acc. to standard EN 50178).

### **Impermissible applications**

- in life-sustaining medical devices or machines
- connection to dc power supplies without over-voltage protection circuits
- on ships
- in explosive environments
- in environments with acrid fumes

# Basic information

## 2.13 Regulations and guidelines

The device and its associated components can only be installed and switched on where the local regulations and technical standards have been strictly adhered to:

EU Guidelines	2004/108/EG, 2006/95/EG, 2006/42/EG, 2002/96/EG
EU Standards	EN60204-1, EN292, EN 50178, EN60439-1, EN61800-3, ECE-R100
International standards	ISO 6469, ISO 26262, ISO 16750, ISO 20653, ISO 12100
IEC/UL Regulations	IEC 61508, IEC364, IEC 664, UL508C, UL840
VDE Regulations and TÜV Regulations	VDE 100, VDE 110, VDE 160
Regulations of the statutory accident insurance and prevention institution	VGB4

### EU standards and regulations observed for the components of the unit

Standard	Description	Version
EN 60146-1,-2	Semiconductor converters	2010
EN 61800-1,-2,-3	Speed-variable electrical drives	2010
EN 61800-5-1	Electric power drive systems	2010
EN 60664-1	Isolation coordinates - low voltage	2012
EN 61010	Safety regulations - control units	2011
EN 61508-5	Functional safety of electric, electronic systems	2011
EN 60068-1,-2	Environmental influences	2011
ISO 20653	Type of protection of the electrical equipment of vehicles	
ECE-R100	Conditions for battery-driven electric vehicles	
UL 508 C	UL Regulations - converter	2002
UL 840	UL Regulation - clearance and creepage distances	2005

### EU standards and regulations which must be observed by the user

Standard	Description	Version
EN 60204	Safety and electrical equipment of machines	2011
EN 50178	Equipment of power plants	1998
EN 61800-3	Speed-variable electric drives - EMC	2010
EN 60439	Low voltage switching device combinations	2011
EN 1175-1	Safety of electric industrial trucks	2011
ISO 6469	Electric road vehicles	2009
ISO 26262	Functional safety of electric road vehicles	2011
ISO 16750	Elektrical components - vehicles	2010
ISO 12100	Safety of machines	2011
ISO 13849	Safety of machines and controls	2011
IEC 364	Protection against electric shocks	2010
IEC 664	Isolation coordinates - low voltage	2011

## 2.14 Risks

The manufacturer aims to keep the remaining risks emanating from the unit as low as possible by means of constructive, electrical, and software measures.

In the field of drive engineering the following known remaining risks must be considered regarding the risks arising from machines, vehicles, and installations.

### Impermissible movements

caused by:

- failure of safety watchdogs or switched-off safety watchdogs during commissioning or repair works
- software errors in upstream controls, errors in bus systems
- non-monitored hardware and software errors in actuating elements and connecting cables
- inverted sense of control
- faults during the parameter setting and wiring
- limited response time of the control features
- operations not permitted in the specifications
- electromagnetic interferences
- electrostatic interferences, lightning strikes
- failure of components
- failure in the brakes



### Dangerous temperatures

caused by:

- faults during the installation
- faulty connections, bad contacts, aging
- faults in the electric safety system, incorrect types of fuses
- operations not permitted in the specifications
- negative climatic conditions, lightning strikes
- failure of components

### Dangerous voltages

caused by:

- faulty earthing of the unit or motor
- faulty connections, bad contacts, aging
- faulty potential isolation, failure of components
- conductive contamination, condensation



### Dangerous fields

The units, the inductive and capacitive accessories as well as the power wiring can generate strong electric and electromagnetic fields. These fields may be dangerous for persons having electronic medical aids or appliances (e.g. cardiac pacemakers). Sufficient distance to these electrical parts must be observed.



# Basic information

## 2.15 Technical data

### For battery voltages up to 48V=

Power supply connection	12 V= to 48 V= Please indicate battery voltage on order!	
Auxiliary voltage connection	12 V= to 24 V ± 10 % / 2 A	residual ripple <10 % regenerating fuse

BAMOBIL D3-IM-62	Dimensions	120	250	450
Supply voltage	V=	12 to 48		
Max. output voltage	V~eff.	3 x 7 to 3 x 33		
Continuous current	A eff.	60	125	225
Max. peak current	A IO	120	250	450
Max. power loss	W	300	600	1200
Pulse frequency	kHz	programmable 8-24		
Over-voltage switching threshold	V=	programmable up to max. 72 V		
Input fuse	A	160	250	350
Bus circuit capacity	µF	28200		
Weight	kg	6.8		
Dimensions h x w x d	mm	280 x 200 x 90		

### For battery voltages up to 120V=

Power supply connection	12 V= to 120 V= Please indicate battery voltage on order!	
Auxiliary voltage connection	12 V= to 24 V ± 10 % / 2 A	residual ripple <10 % regenerating fuse

BAMOBIL D3-IM-160-	Dimensions	100	200	300
Supply voltage	V=	12 to 120		
Max. output voltage	V~eff.	3 x 7 to 3 x 78		
Continuous current	A eff.	50	100	150
Max. peak current	A IO	100	200	300
Max. power loss	W	300	600	1200
Pulse frequency	kHz	programmable 8-24		
Over-voltage switching threshold	V=	programmable up to max. 160V		
Input fuse	A	160	250	350
Bus circuit capacity	µF	9000		
Weight	kg	6.8		
Dimensions h x w x d	mm	280 x 200 x 90		



## Basic information

Control signals	V	A	Function	Connector
Analogue inputs	±10	0.005	Differential input	X1
Digital inputs - ON	10-30	0.010	Logic IO	X1
OFF	<6	0		
Digital outputs	+24	1	Transistor output open emitter	X1
Analog output	±10		Operational amplifier	X1
Resolver, TTL, SINCOS			Differential input	X7
CAN interface			logic IO	X9
RS232 interface			logic IO	X10

Ambiant conditions	
Protection rating	IP65
Standards	EN60204, EN61800, IEC60146
Operating temperature range	-10 to +45 °C
Extended operating temperature range	from +45 °C to +60°C performance reduced by 2%/°C
Storage and transport	-30 °C to +80 °C EN60721
Site of installation	≤ 1000 m above sea level 100 %, >1000 m performance reduced by 2 % / 100 m
Cooling	with additional cooling unit
Mounting position	arbitrary
Contamination	Contamination degree 2 acc. to EN61800-5-1
Oscillation	10 Hz to 58 Hz amplitude 0.075 mm (IEC 60068-2-3) 58 Hz to 200 Hz 1 g
Shock	15 g for 11 ms
Environmental conditions	<b>Not permissible:</b> condensation (dew), ice formation, oil mist, salt spray, water
Humidity range	class F, humidity <85 % <b>no condensation allowed!</b>

Power supply cables between the BAMOBIL and the battery must be as short as possible. Long cables cause dynamic voltage drops due to the line impedance and as a consequence the service life of the installed ELKOs would be reduced.



## Reduktion Strom und Leistung

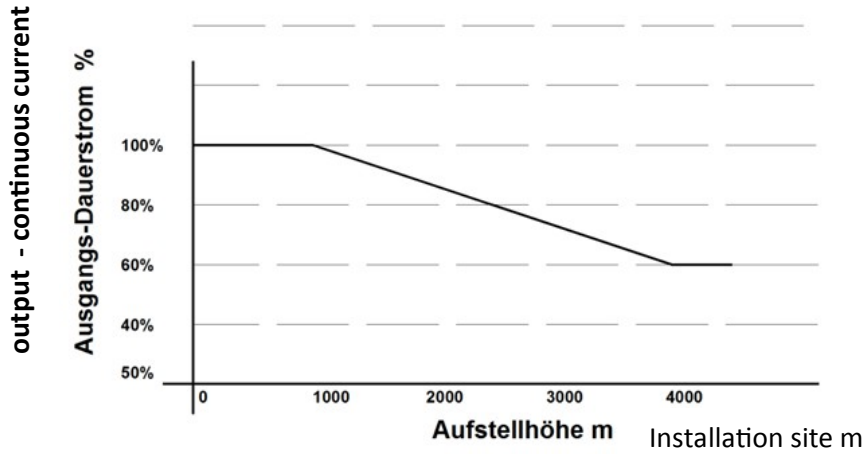

Current reduction as a function of the installation site

Zchn-DS4-Strom-Reduktion-Höhe-2

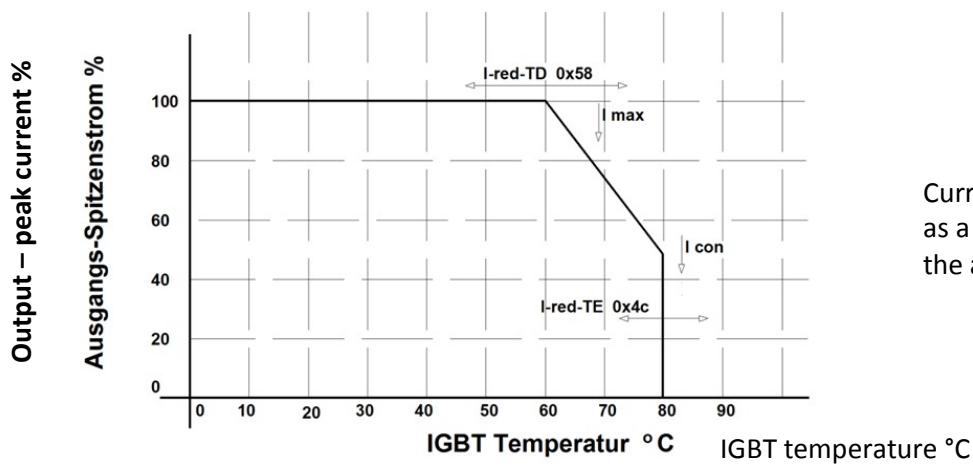

Current reduction as a function of the ambient temperature

Zchn-DS4-Strom-Reduktion-Umgebung-Temperatur-2

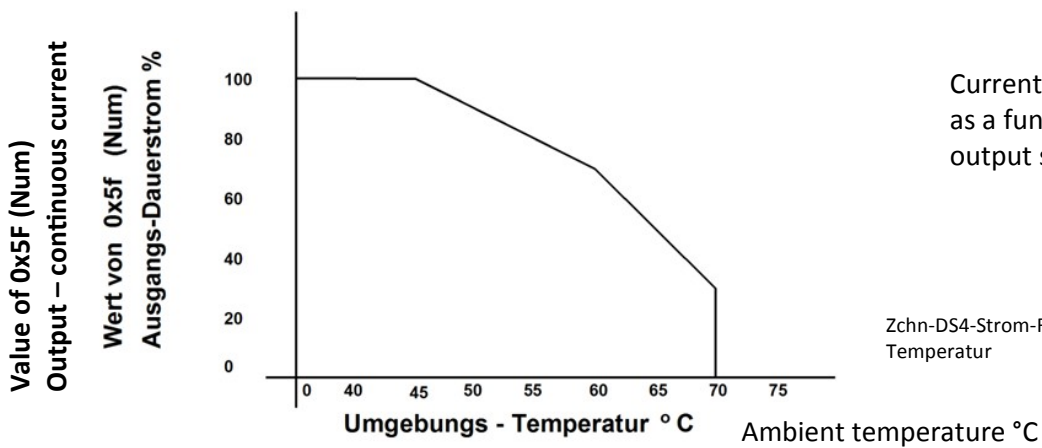

Current reduction as a function of the output stage temperature

Zchn-DS4-Strom-Reduktion-IGBT-Temperatur

## Basic information

### Losses with version **-62** (power supply 12 to 48 V)

losses of the output stage

$I_{rms}$  = RMS value of the current demand at max. load cycle

R-FET = Max. forward resistance at the FET bridge arm

Cooling capacity base plate 10mm with aluminium housing = 1.7°C/Watt

internal threshold temperature 85°C

$$\text{Power loss} = 2 \cdot R\text{-FET} \cdot I_{rms}^2$$

Example 1: Device BAMOBIL D3- <b>IM</b> - 62-250 R-FET = 1.2 mΩ $I_{rms}$ approx. 80 A	Example 2: Device BAMOBIL D3- <b>IM</b> - 62-250 R-FET = 1.2 mΩ $I_{rms}$ approx. 120 A
Power loss: $0.0024 \cdot 80^2 = 15$ Watt Heating: $1.7 \cdot 15 = 25.5$ °C Final temperature at 35°C ambient temperature = 60.5 °C An additional cooling surface is <b>not</b> necessary.	Power loss: $0.0024 \cdot 120^2 = 34.6$ Watt Heating: $1.7 \cdot 34.6 = 58.8$ °C Final temperature at 60°C ambient temperature = 118.8°C An additional cooling surface is necessary. Additional air or liquid cooling unit.

### Losses with version **-160** (power supply 12 to 120 V)

Losses of the output stage

$I_{rms}$  = RMS value of the current demand at max. load cycle

R-FET = Max. forward resistance at the FET bridge arm

Cooling capacity base plate 10mm with aluminium housing = 1.7°C / Watt

internal threshold temperature 85°C

$$\text{Power loss} = 2 \cdot R\text{-FET} \cdot I_{rms}^2$$

Example 1: Device BAMOBIL D3- <b>IM</b> - 60-200 R-FET = 4 mΩ $I_{rms}$ approx. 80 A (chosen)	Example 2: Device BAMOBIL D3- <b>IM</b> -160-200 R-FET = 4 mΩ $I_{rms}$ approx. 120 A (chosen)
Power loss: $0.004 \cdot 80^2 = 25.6$ Watt Heating: $1.7 \cdot 25.6 = 30.7$ °C Final temperature at 35°C ambient temperature = 65.7 °C An additional cooling surface is <b>not</b> necessary.	Power loss: $0.004 \cdot 100^2 = 40$ Watt Heating: $1.7 \cdot 40 = 68$ °C Final temperature at 60°C ambient temperature = 128 °C An additional cooling surface is necessary. Additional air or liquid cooling unit.

### Forward resistance FET arm

BAMOBIL	62-80	62-120	62-250	62-450	160-100	160-200	160-300
R-FET mΩ	3.5	1.2	1.2	1.2	4	4	4

### Cooling capacity - additional cooling unit

Cooling unit type	Thermal resistance	Weight
Air cooler (natural convection)	0.4 °/W	2.0 kg
Air cooler (ventilator)	0.07 °/W	2.5 kg
Liquid cooler	0.012 °/W (2l/min, 0.8psi)	1.2 kg

## 3 Mechanical installation

### 3.1 Important instruction

Check the device for mechanical damage.  
Only devices in perfect working order can be mounted.

Disconnect the power supply prior to any assembly.  
Disconnect the positive and negative battery pole and the dc mains.  
The device must only be mounted by suitably trained personnel.

The mounting position of the devices with ground plate and those with additional cooling unit (air by means of fan, liquid) is arbitrary.

Devices with an additional cooling unit without a fan must be mounted vertically. Please note that there will be a performance reduction when they are mounted horizontally.  
Ensure that the ventilation is sufficient and that there is enough space for the discharged ventilation air (min. 100 mm). If the heat is not dissipated sufficiently the device switches off via its temperature watchdog.



Any bore hole dimensions for the fixation of the device must be taken from the dimension diagrams or from the drilling plan, not from the device.

The filter and the choke have to be mounted near to the device.

The line shields and the mounting plate must have surface-to-surface contact.  
The power supply lines (battery line and motor line) must be routed separately from each other.  
Observe the min. line cross-section.

A safe earth connection must be provided between the housing and the mass level (vehicle chassis earth, earth of the switch cabinet)

Unshielded cable heads must be kept short.

10 mm cable lugs

Use vibration-proof screw connections.



## 3.2 Dimensions BAMOBIL D3-IM

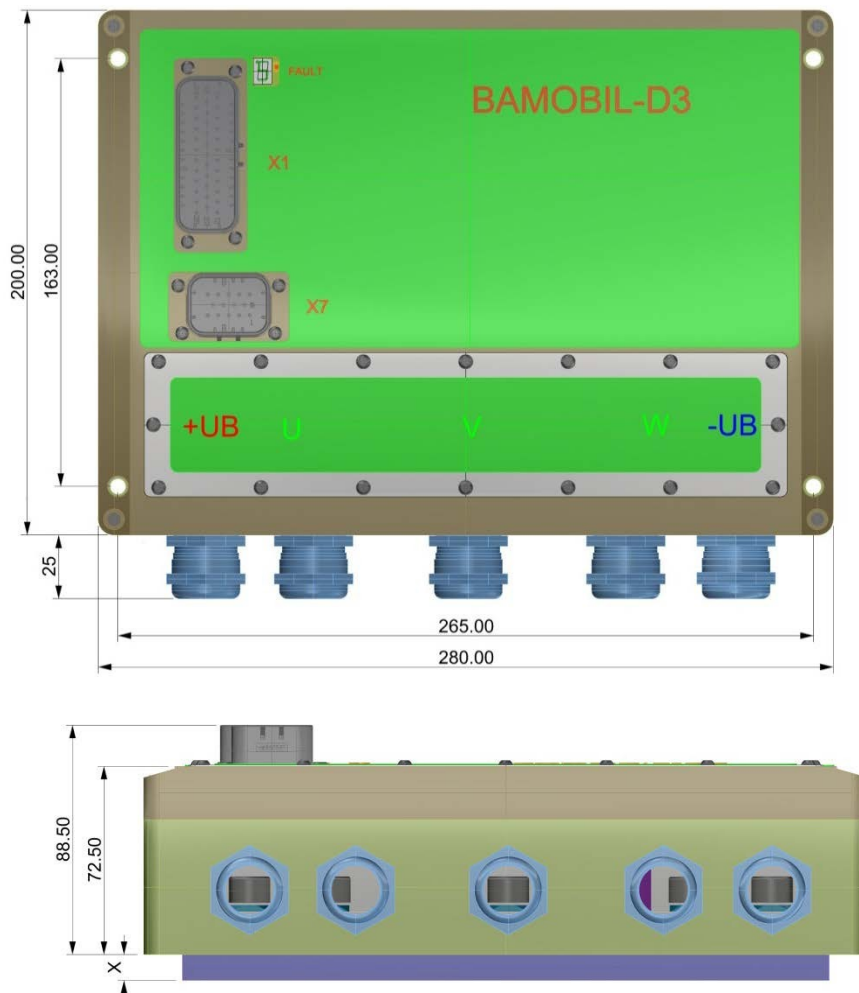

Bamobil-D3-IM-Massbild-seit

Depth with connector and cable 150 mm  
Cooling element at 300 A = 10 mm, > 300 A = 20mm  
Thermal resistance 1.7°/W

Fixing screw: BAMOBIL D3-IM M4x20  
Screws for power connections / Allen-Key M10x16 / Maximum tightening torque 15 Nm

If the mounting plate (without the additional cooling unit ) is mounted onto the rear panel of the switch cabinet (4mm bright steel) and the ambient temperature is 45°C, the cooling capacity of the plate corresponds to:

- a continuous current of 60  $A_{rms}$  (S1 duty) with BAMOBIL D3-63
- a continuous current of 45  $A_{rms}$  (S1 duty) with BAMOBIL D3-160

For superior currents (for intermittent duty S2, S3) it is necessary to provide an additional cooling unit (air or liquid) or a heat dissipating mounting plate.

**Cable screw glands M25x1.5 and Tyco connectors are not included in the delivery scope.**

## 3.3 Power connections

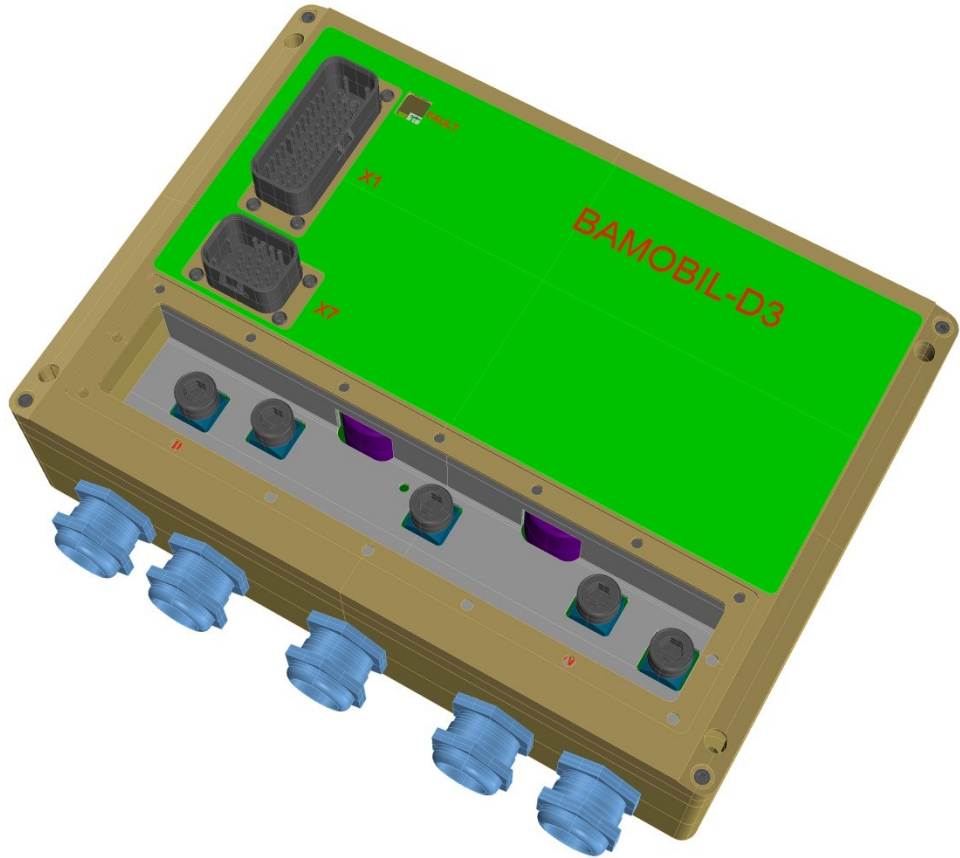

Bamobil-D3-IM-V2-2

## 3.4 Additional cooler

### Liquid cooler

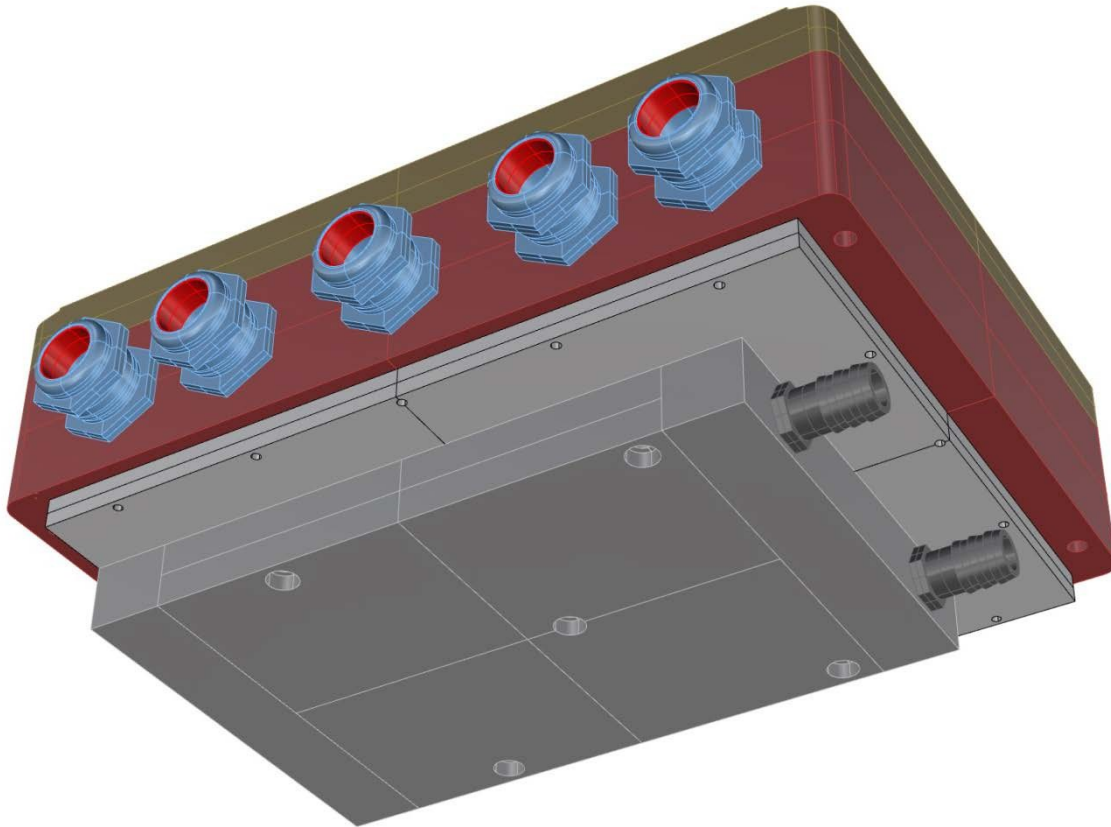

Bamobil-D3-IM-wakü-1

Thermal resistance	0.012 °K/W
Weight	1.2 kg
Coolant connection	¼ Zoll

## Air cooler

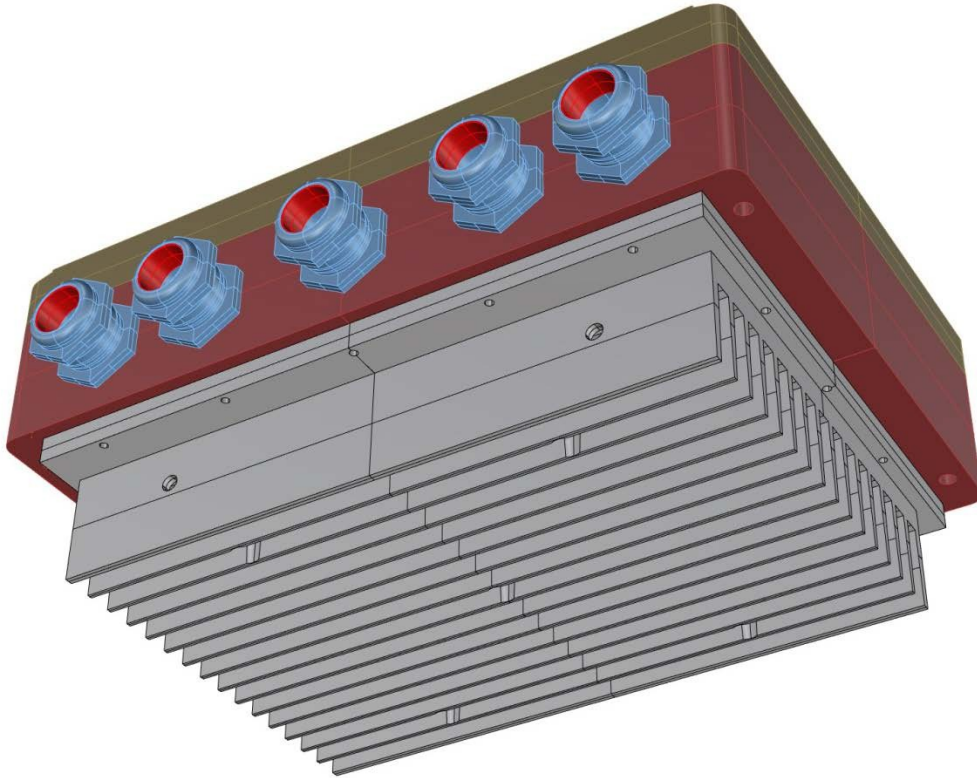

Thermal resistance 0.. °K/W  
Weight 2 kg

Bamobil-D3-IM-Lukü-1

## Air cooler with fan

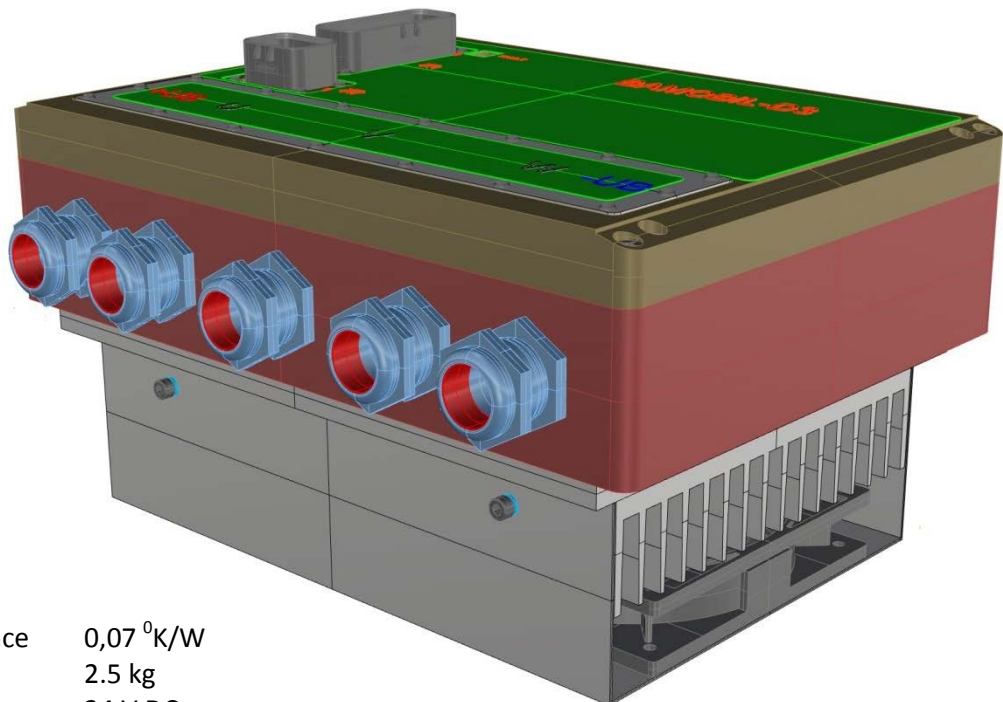

Thermal resistance 0,07 °K/W  
Weight 2.5 kg  
Fan connecton 24 V DC

Bamobil-D3-IM-Lukülu-1



## 4 Electrical installation

### 4.1 Important advices

**The order of the connections to the connector or terminal numbers is obligatory!**

All further advice is non-obligatory.

The input and output conductors may be altered or supplemented in accordance with the electrical standards and guidelines.

Adhere to:

- connection and operating instructions
- local regulations
- EU guideline 2996/42/EC
- guidelines for vehicles ECE-R100, ISO 6469, ISO 26262
- VDE and TÜV regulations and Trade body guidelines

**Electrical installation should only be carried out when all voltages have been removed!**

Ensure that the device is safely disconnected from the power supply

- place the short-circuit bracket
- affix warning signs

The installation should only be carried out by suitably trained personnel for electrical engineering.



Compare the connection data with those indicated on the type plate.

Ensure that the correct fuses have been provided for the power supply and the auxiliary voltage.

Power supply conductors and control lines must be routed separately from each other.

Connection shields and grounding must be carried out in compliance with the EMC guidelines.

Use the correct line cross-sections.

### Insert external isolation monitors!

**Note:** Bad or insufficiently rated cable connections between the battery and the device may cause damage to the device! (Brake energy)

**Note:** Power supply cables between the BAMOBIL and the battery must be as short as possible. Long cables cause dynamic voltage drops due to the line impedance and as a consequence the service life of the installed ELKOs would be reduced.

#### **Static charging voltage (ESD):**

ESD voltages must not arise between the potentials and against earth. Take appropriate protective measures!

For voltages >60 V a protection against accidental contact with exposed parts must be installed.

Use a pre-charging circuit (manufacturer Inrush limiter).



## 4.2 Circuit diagram

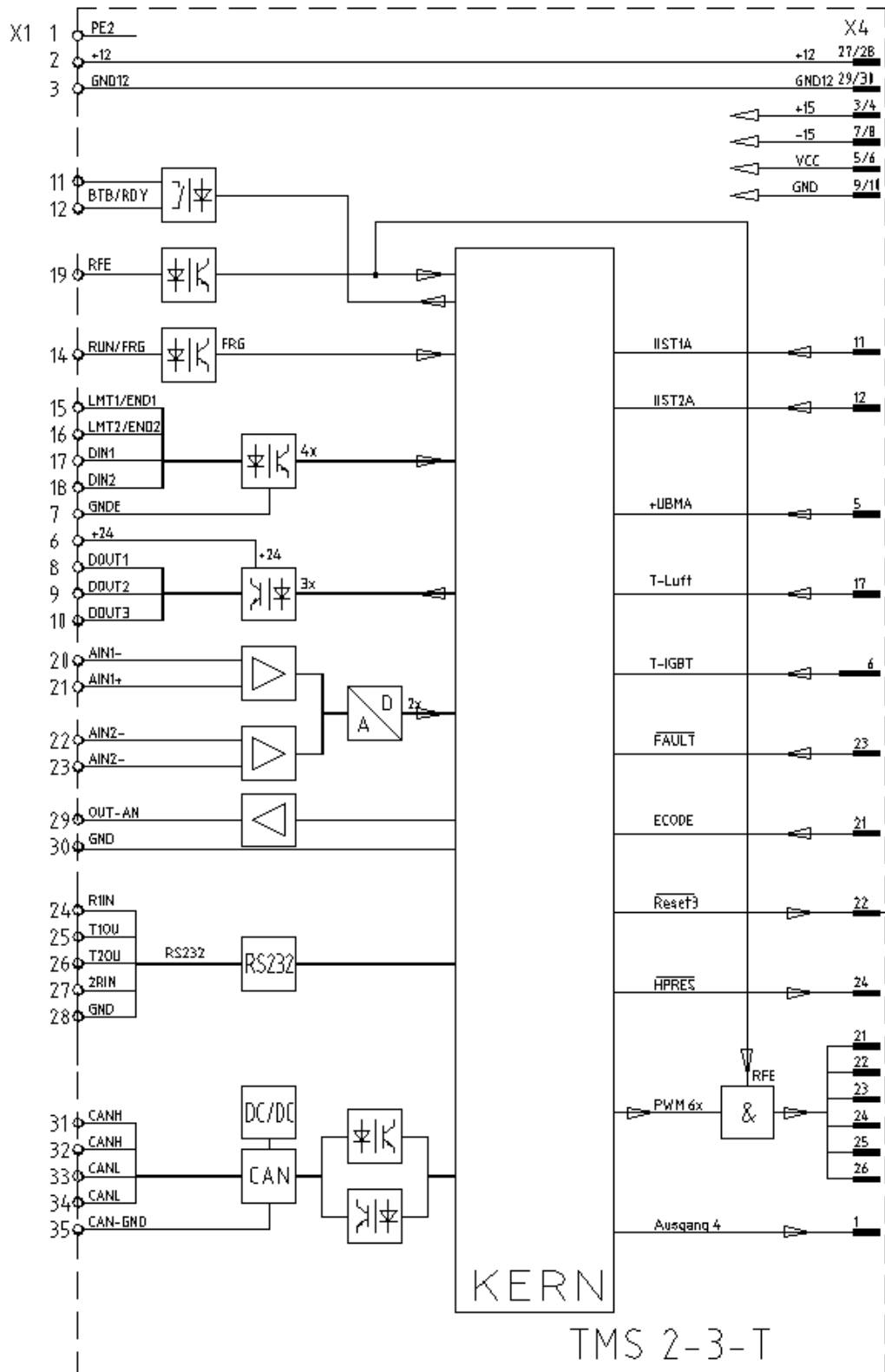

Drawing on page 1 of 2

Bamobilxx-blockbild-TMS-3

## Circuit diagram

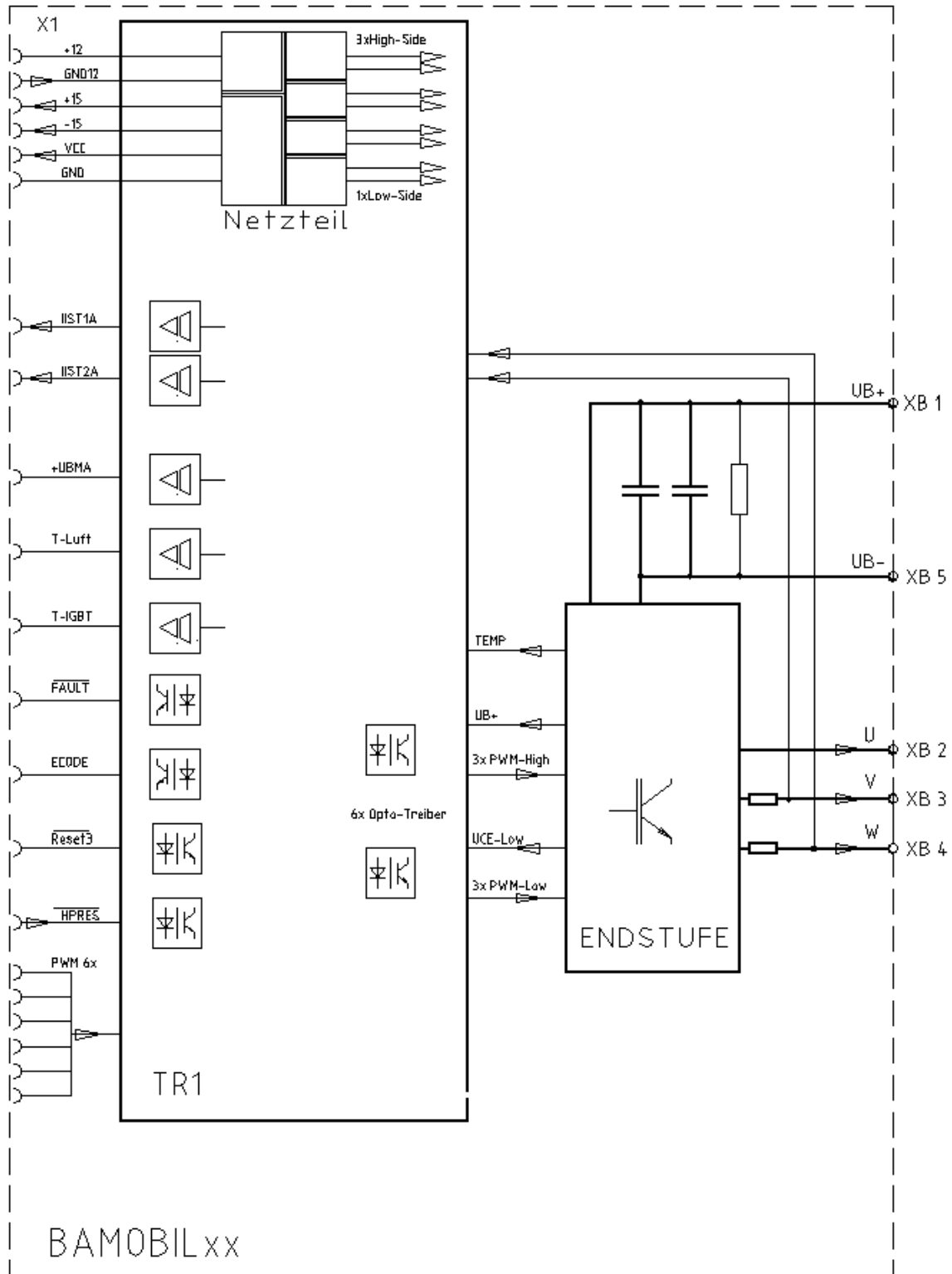

## 4.3 Connection diagram

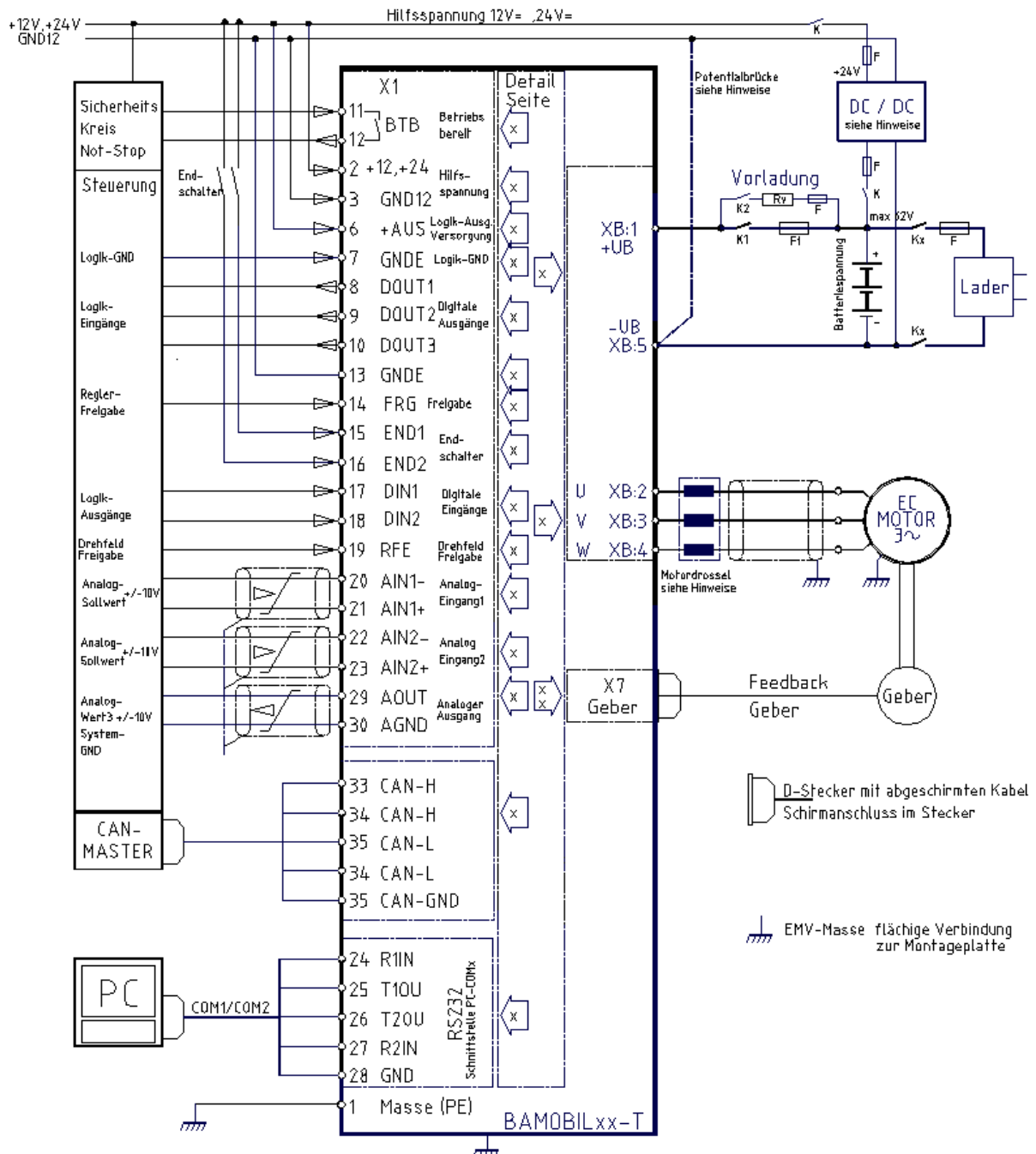

Bamobilxx-Tyco-D3-2-anschlussplan-4

## 4.4 EMV advice

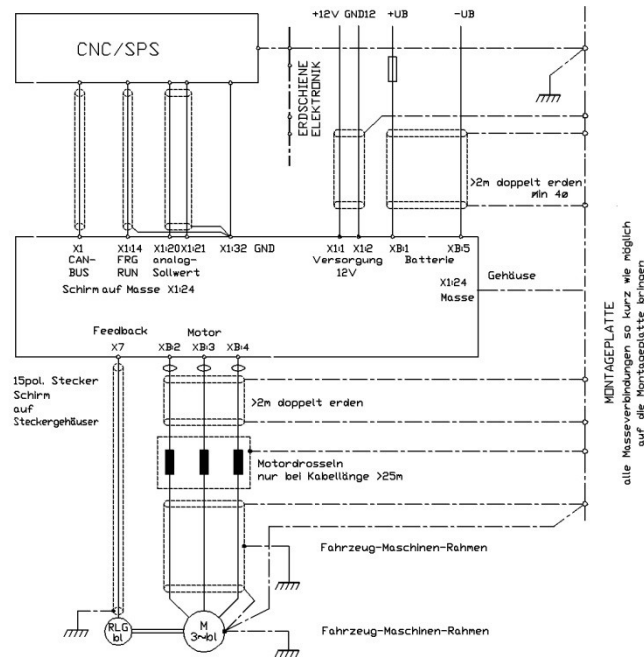

Bamobil65-emv-1

The devices adhere to the EU guidelines 2004/108/EC and the technical standard EN 61800-3 provided that the following conditions are observed:

### Mounting:

The device is conductively mounted on a 500 x 500 x 5 mm bright aluminium mounting plate. The mounting plate must be connected to  $-U_b$  using a 10mm<sup>2</sup> wire. The motor housing must be connected to  $-U_b$  using a 10mm<sup>2</sup> wire. The device ground X-AGND must be connected to the mounting plate using a 1.5 mm<sup>2</sup> wire. The housing must be connected to the mounting plate (earth).

### Connection of the control conductors:

All control conductors must be shielded. Analogue signal lines must be twisted and shielded. The shield must have surface-to-surface contact with the mounting plate (earth).

**Battery connection:** 120 V dc voltage

### Motor connection:

Motor lines must be shielded, and must have surface-to-surface contact with the mounting plate (earth).

After having been mounted in vehicles, machines, and installations the operation of the device must not be started until the machine or the installation has been approved of the regulations of the EC machine guideline 2006/42/EC and the EMC guideline 2004/108/EC, for vehicles ECE-R83 and ECE-R100. A manufacturer's declaration can be asked for.



## Potential separation

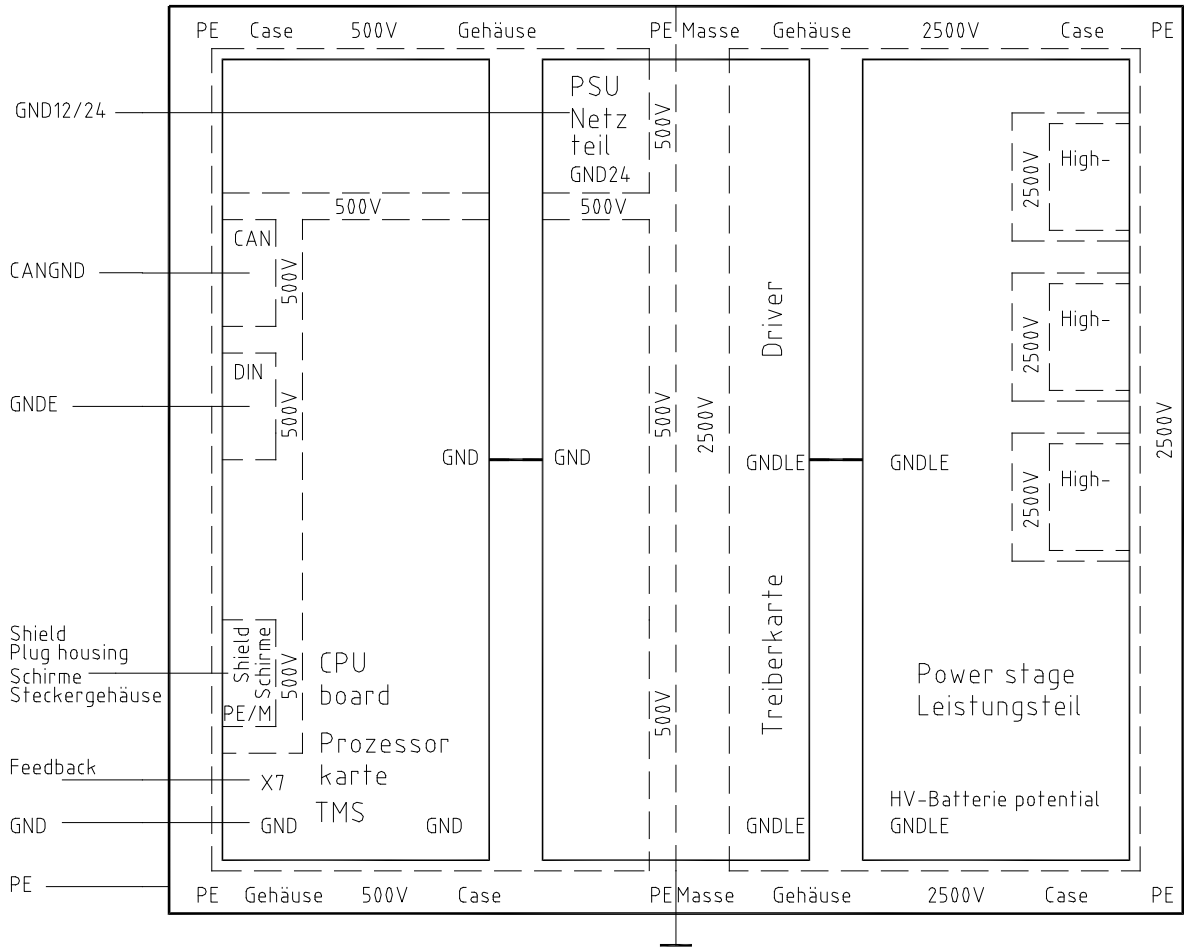

Bamobil-D3-IM-potential-1

## 4.5 Connectors X1 ,X7

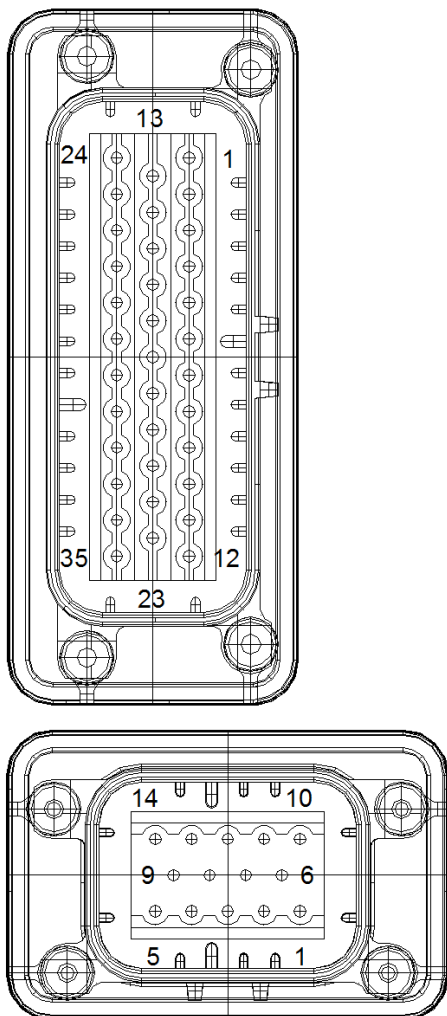

Connectors X1 control inputs / outputs		
1	PE2	
2.	+24V	Auxiliary voltage +
3	GND24	Auxiliary voltage 0
4	nc	
5	nc	
6	+ AUS	Supply outputs
7	GNDE	GNDE Outputs
8	DOUT1	Digi-Output1
9	DOUT2	Digi-Output2
10	DOUT3	Digi-Output3
11	BTB	Operational
12	BTB	Operational
13	GNDE	GNDE Input
14	FRG	Release
15	END1	Limit switch1
16	END2	Limit switch2
17	DIN1	Digi-Input1
18	DIN2	Digi-Input2
19	RFE	Rotor Enable
20	AR1	Analog Input 1-
21	AIN1	Analog Input 1+
22	AR2	Analog Input 2-
23	AIN2	Analog Input 2+
RS232		
24	R1IN	RS232
25	T1OU	RS232
26	T2OU	RS232
27	R2IN	RS232
28	GND	Analog GND
Analog Ausgang		
29	DAC1	Analog output
30	GND	Analog GND
CAN-BUS		
31,32	CAN H	
33,34	CAN L	
35	CAN-GND	

Connector 35pol: Tyco 776164-1

Connector 14pol: Tyco 776273-1

(Bamobil65-stecker-tyco-1)

Connector X7 Encoder connector resolver	
1	
2	SIN1
3	COS2
4	REF1
5	
6	Temp GND
7	
8	
9	
10	
11	Temp Signal
12	REF1
13	COS1
14	SIN2

Connector X7 Encoder connector INC-TTL	
1	channel A
2	channel B
3	channel N
4	channel /A
5	GND
6	GND Temp
7	
8	channel /N
9	+5 VCC
10	channel /B
11	Temp Signal
12	Rotor position1
13	Rotor position 2
14	Rotor position 3

Conneccotr X7 Encoder connector SINCOS	
1	ka+
2	kb+
3	kr+
4	ka-
5	GND
6	GND Temp
7	kd+
8	kr--
9	+5 VCC
10	kb-
11	Temp-signal
12	kd-
13	kc+
14	kc-

## 4.6 Battery connection

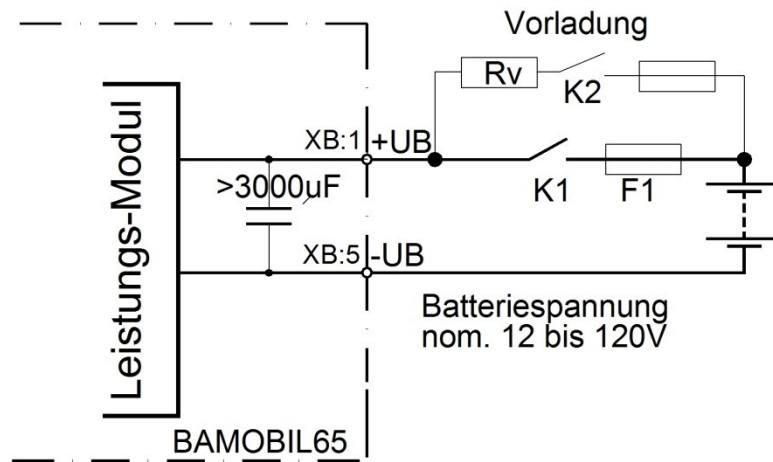

BAC65-T-Batterie-1

### Pre-charging circuit must be used.

When directly switching on K1 the charging current may be up to 5kA.

Bus circuit min. 6000 µF

Series resistor

RV approx. 10 Ohm 10 W

Charging current via K2 < 16 A

Charging time max. 0.5 s

Switching delay for K1 by means of a time-lag relay (2 seconds after K2) oder by means of a bus circuit monitoring.

### Attention:

The main contactor (K1) must only be switched when the BAMOBIL is blocked (enable X1:7 FRG = 0 V)!

### Switch-on sequence:

Auxiliary voltage on, (command value 0), min. 5s later power voltage on, min. 2s later enable on.

### Switch-off sequence:

(Command value 0), enable off, min. 2s later power voltage off, auxiliary voltage off.



Always insert BTB / RDY contact in the safety circuit.

In the case of a fault in the battery terminal of the battery must be disconnected (K1 open).

**Fire hazard due to device-internal arc!**



## Basic circuit for the pre-charging

BAC65-5-Vorladung-1

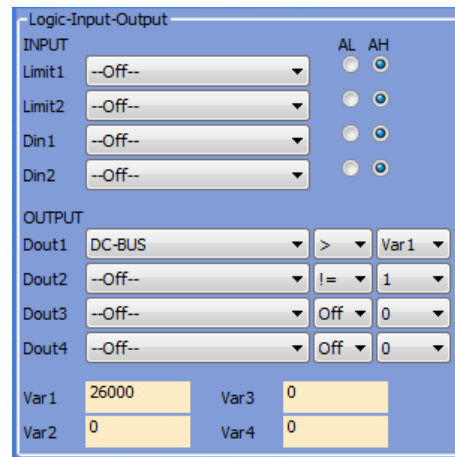
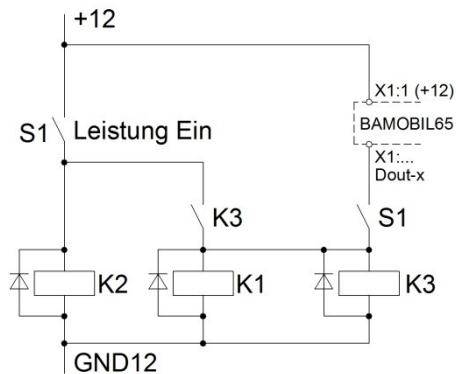

### Programming example:

The output Dout1 switches the relay K3 when the bus circuit voltage DC-BUS ( $I_{o/u}$  voltage) is greater than the variable 1.

### Note:

The parameter DC-BUS min must be programmed to min. battery voltage (permitted discharge voltage). (100 % correspond to 48 V)

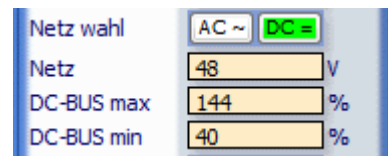

### Warning

The max. supply voltage (72 V=, 160 V=) must not be exceeded at any time (not even for short intervals)!

#### Danger of damage!

F1 = safety fuses

The power supply connection has no protection against reverse polarity.

If the polarity of the connection is wrong, the device will be destroyed!



Type	Battery connection bolt 12V to 120V= bolt M10x16	Connector cross-section		Fuse A		
	Anzugsmoment					
-100, 120	<12 Nm	16	4	160		
-200, 250	XB1 (+UB=)	25	4	250		
-300	XB5 (-UB=)	50	1	350		
-450		70	2/0	450		

**Battery connecting line <2 m. For conductor lengths from 2 to 10m more powerful. Use an additional capacity for conductor lengths superior to 10m!**

# Electrical installation

## Auxiliary voltage connection

Mains potential-free auxiliary

dc voltage 12 V= to 24 V=±10 % / 2 A

The auxiliary voltage is galvanically separated from all other voltages.

- internal regenerating fuse
- EMC filter
- external fuse only for the line protection

Input voltage	12V to 24V= DC
	X1:4
	GND24 X1:3
Residual ripple1	10 %
Switch-on current	2A
Nominal current	0.8A

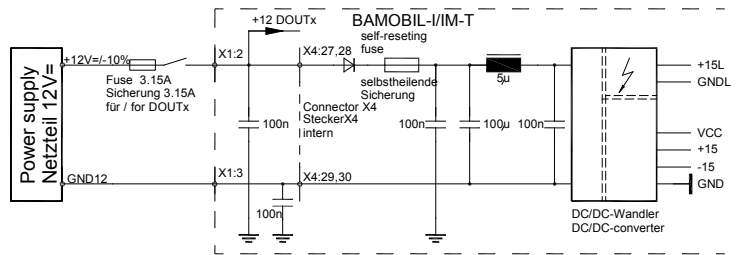

BAC-I-T-Hilfsspannung-1

**Note:** Connect the auxiliary voltage only to a stable 12 V-24 V voltage supply source (battery or mains unit).

**Attention:** In addition to the internal supply current (0.8A) the sum of the output currents (DOUT) must be provided by the mains module 12 V.

**Attention:** If the auxiliary voltage is inferior to 10 V - even in case of short-time voltage drop-outs - the internal mains module is switched off. Any data of the RAM are deleted! The speed and the position command values are set to zero and any calibrated data are deleted.

**The LED signal for the state "OK" is dark.**



**Attention:** Firmware download only when the power supply is switched off. The auxiliary voltage and/or power supply voltage must only be switched when the BAMBIL is disabled. Enable input X1:14 = zero

## 4.7 Motor power connection

Only electronically commutating synchronous motors (brushless dc motors, EC motors) with resolver or incremental encoder must be used. These motors must be approved of by manufacturer prior to any use. See Motor specific connection and parameter standards and guidelines.

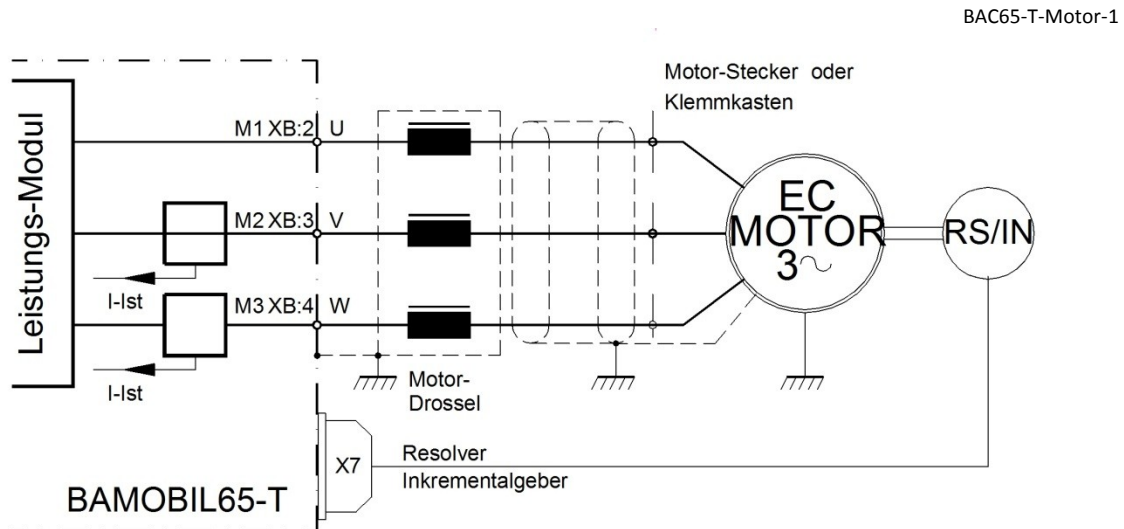

### Sequence of connection

<b>Cable</b>	M1	M2	M3	<b>Motor cable</b> shielded for 200 V=, shield capacity = 150 pF/m min. cross-section see below table
<b>Motor phase</b>	U	V	W	
<b>Connecting bolt</b>	XB:2	XB:3	XB:4	
<b>Only one correct connecting sequence is possible!</b>				

### Min. cable cross-section

<b>Type BAMOBIL D3-IM</b>			<b>-100</b>	<b>-120</b>	<b>-200</b>	<b>-250</b>	<b>-300</b>	<b>-450</b>
<b>Cross-section mm<sup>2</sup></b>			6	10	25	35	50	70
<b>AWG</b>			10	6	4	2	1	2/0

### Note:

Any motor cable cores which are not used must be connected to earth.  
Dangerous voltages may arise due to capacitive coupling of the clocked motor cores.

### Motor choke

Only necessary for a shield capacity of >5 nF. Approx. 25 m motor cable

### Magnetic rings

against HF failures of the sensor systems. Slide the rings onto the motor lines.

### Connection of the shield

Surface-to-surface connection to the cable screw gland of the BAMOBIL D3xx.  
Surface-to-surface connection as short as possible to the motor side.



## 4.8 Control signals

### Digital inputs / 6 optocoupler inputs

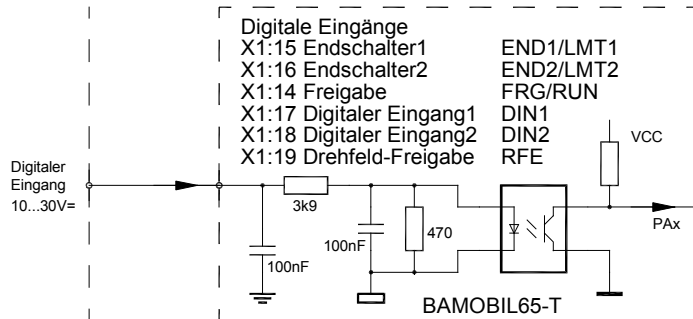

BAC65-T-DIN-1

Input voltage		
Level ON		+10 to +30 V
Level OFF		<+6 V
Input current	Max.	7.5 mA
Nominal voltage/current		+24 V / 6 mA
Ground reference	GNDE	(X1:7)

The enable input (FRG/RUN) and the input for the rotating field enable (RFE) are fixed, they cannot be programmed.

Without the enable FRG/RUN the servo-drive is electronically disabled (no PWM pulses).

Without the rotating field enable RFE the rotating field of the output stage is additionally electronically disabled (2<sup>nd</sup> disable channel).

The drive is free of torque (no holding torque).

The remaining four digital inputs can be programmed.

The inputs LMT1 (X1:5) and LMT2 (X1:6) are preferably to be used as inputs of the output stage switch.

Input	Connector	Function	State	Parameter
FRG/RUN	X1:14	Enable	fixed	
RFE	X1:19	Rotating field enable	fixed	
END1/LMT1	X1:15	Output stage switch 1 / digital input	programmable	
END2/LMT2	X1:16	Output stage switch 2 / digital input		
DIN1	X1:17	Digital input 1		
DIN2	X1:18	Digital input 2		

### External power supply for the inputs and outputs

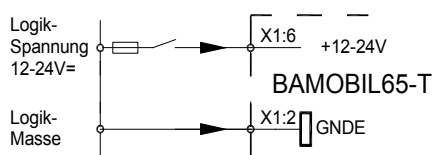

BAC65-T-Logikspannung-1

+24 V for the logic and the auxiliary voltage  
Observe the total current of all outputs.

GNDE logic ground

## 4.9 Safety input RFE (Rotating field enable)

### Warning:

If the input of the enable or of the rotating field enable are switched off, the drive is free of torque. The drive could move if there is no mechanical brake or block provided.



The motor conductors are not dead. Only the rotating field is disabled. Prior to any work or maintenance on the motor or servo-drive, the servo-drive must be completely disconnected from the mains power supply.

### Operation with an RFE input

Two-channel disable of the enable via a safety switching device.  
 Enable input FRG/RUN +  
 Rotating field enable input RFE.

### Switching-on

Contacts of the safety device closed, enable FRG/RUN 0.5 s after RFE.

### Safety switch-off

- Contacts of the safety device open:
- there is no FRG/RUN signal in the 1<sup>st</sup> disable channel to disable the PWM pulses in the processor
  - there is no RFE signal in the 2<sup>nd</sup> disable channel to disable the PWM pulses at the output of the processor

### Restart

Release the safety switching device.  
 Contacts of the safety device closed.  
 The motor can only move after a second disable FRG/RUN (after the rotating field enable).

### Operation without RFE input

The input RFE must be bridged with the logic voltage.

If the logic voltage corresponds to the supply voltage, the RFE input is bridged with +24V.

Enable FRG/RUN at least 0.5 s after the RFE signal.

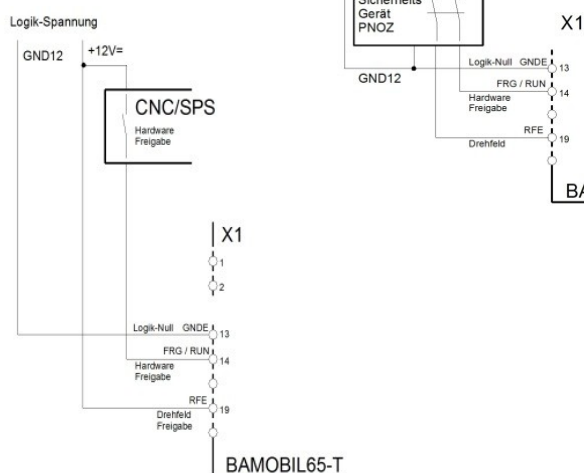
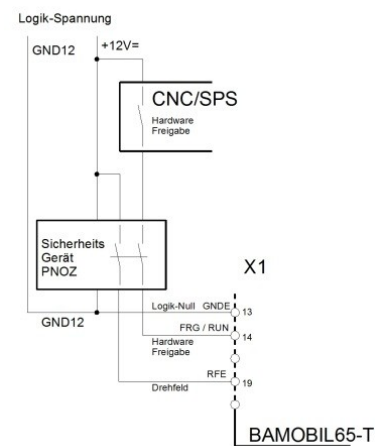
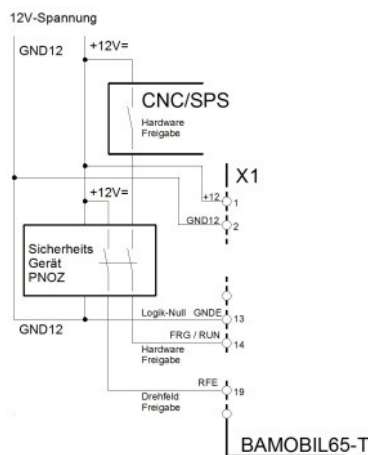

BAC65-5-RFE1-1/ BAC65-5-RFE-1-2 / BAC65-RFE-1-3

## 4.10 Digital logic output (open-emitter)

The logic outputs 1 to 3 are rated for 24V and 1A (short-time: 2A).

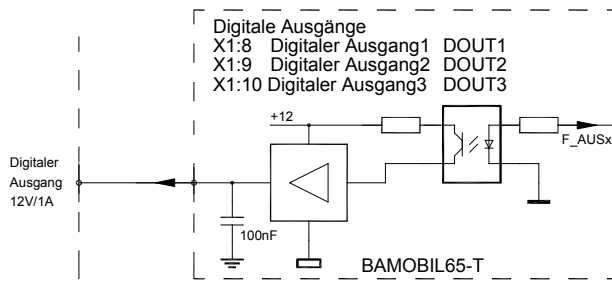

Output voltage			
Level ON	max.	+24 V=	
Level OFF		<1 V=	
Output current	nom	1 A	
Output current	max.	2 A	
Voltage reference	+24	(X1:4)	
+OFF			
Ground reference	GNDE	(X1:7)	

BAC65-6-FOUT-1

It is possible to program an energy saving program (clocked output).

The logic output 4 (24V, 3A) at the power section is only available with certain devices.

## Signal contact "Ready BTB/RDY" (Solid state relay)

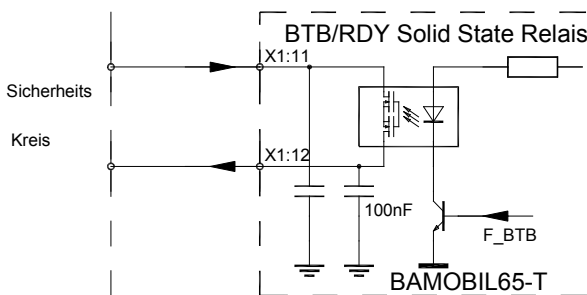

Contact for	max. 48 V / 0.2 A
Capacitive load	max. 1 µF
Contact resistor	max. 2 Ohm

The contact is closed when the device is ready for operation. State signal via seven-segment LED display. In case of failures the contact is open.



**Always install the BTB/RDY contact in the safety circuit!**

BAC65-5-BTB-1

## Ready for operation opens (red LED, open relay contact)

in case of error messages

in case of under-voltage of the auxiliary voltage (<10V)

The message "under-voltage in the bus circuit" can be programmed (see Manual NDrive)

Output	Connection	Function	State	Parameter
BTB/RDY	X1:11, X1:12	ready	fixed/relay	
DOUT1	X1:8	Digital output 1	programmable	
DOUT2	X1:9	Digital output 2	programmable	
DOUT3	X1:10	Digital output 3	programmable	

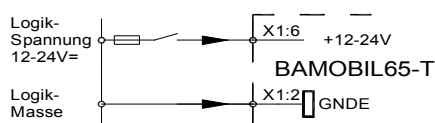

+12-24 V for logic and auxiliary voltage  
GNDE logic ground

BAC-65-5-Logikspannung-1

## Analog input +/- 10V

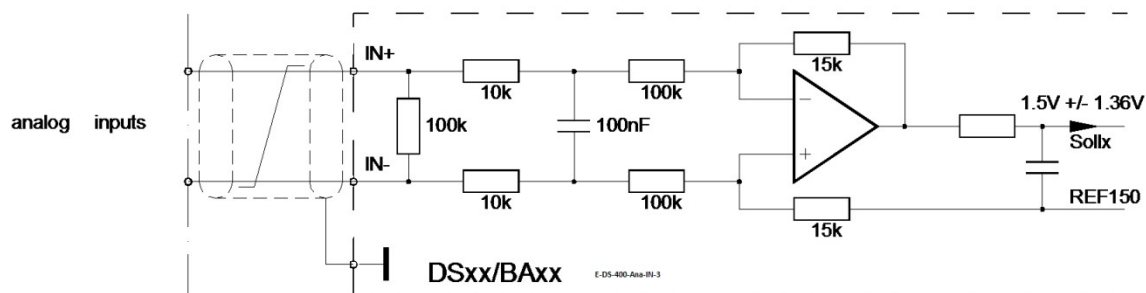

E-DS-400-Ana-In-3

Input	Output	Basic function	Voltage	State	Parameter
AIN1+, AIN1-	X1:20, X1:21	Speed command value	+/- 10 V	prog.	
AIN2+, AIN2-	X1:22, X1:23	Current limit	+/- 10 V	prog.	

## Features

Differential input	AIN1+ / AIN1-	AIN2+ / AIN2-	
Input resistance	70 k		
Threshold voltage	+/- 12 V		
Resolution	11 Bit + sign		

The direction of rotation of the motor can either be changed by swapping the +/- connections at the differential input, or by means of a logic input or by programming.

The analog inputs can be assigned to different functions.

With a digital command value (RS232, x-bus) the analog input AIN1 can be programmed as external analog speed limit and the analog input AIN2 can be programmed as external analog current limit.

## Analog output +/- 10V

Input	Output	Basic function	Voltage	State	Parameter
AOUT1	X1:31	Speed command value	+/-10 V	prog.	
GND	X1:32	Signal zero	0V	fixed	

The analog inputs can be assigned to different functions.

# Electrical installation

## 4.11 Serial Interface RS 232

BAMOBIL-D3 is programmed and operated during commissioning via the serial pc interface RS232. There is a software description in the Manual DS NDrive.

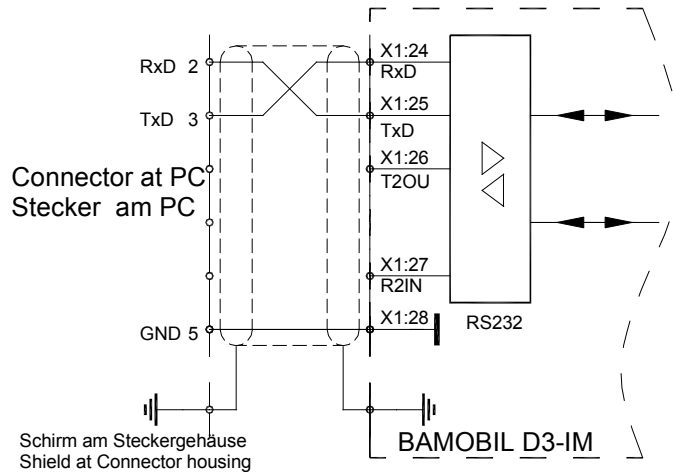

BAC65-5-RS232-2

The BAMOBIL-D3-IM and the serial interface (COMx) of the pc must only be connected using a shielded cable.

Install the cable only after disconnecting the device from the mains.  
 The interface is hard-coded to 115200Baud.  
 The value can be changed to 9600Baud by means of the NDrive.

Connecting cable  
 LiYCY 5x0.25+shield

View to the soldered side,  
 Shield on the housing,  
 Max. cable length 10m.

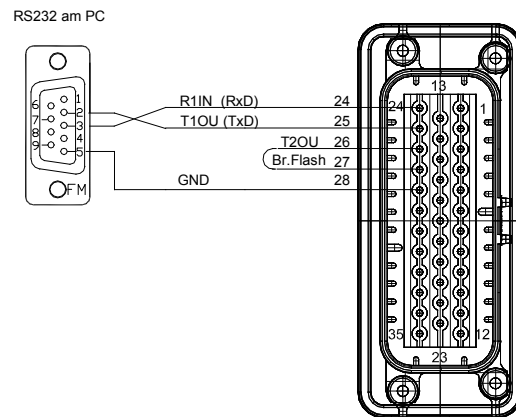

In case of strong interferences at the interface a line filter should be installed.  
 Notebooks with a USB-RS232 converter are usually susceptible to interference.

Install bridge between X1:26 and X1:2 only for Firmware (Flash)

Bamobil65-stecker-RS232-tyco-35-2



## 4.12 CAN BUS

The CAN-BUS is a digital connection to the CNC control.

Optimum conditions are achieved with CNC controls and CAN components of LABOD electronic or CAN Open.

Programming and operation by means of the control panel via the CAN-BUS.

Interface complies with the standard ISO 11898.

Adjustment and programming see Manual DS-CAN.

The BUS interface is galvanically isolated from the internal device voltage.

The voltage is supplied via an internal, isolated DC-DC converter.

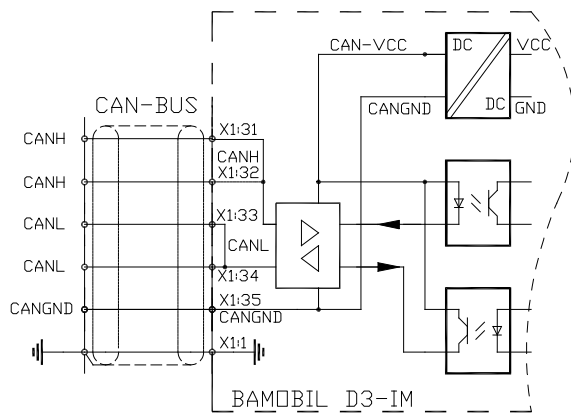

### CAN bus cable

Use a shielded bus conductor with a low shielding capacity.

LiYCY 3x0.25+shield

Bamobil65-CAN-3

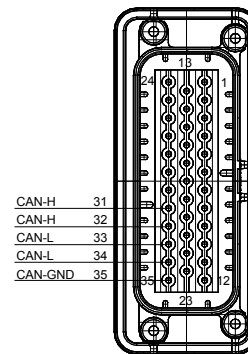

Designation	Connector no.	Cable colour	Cable no.
CAN-H	X1:31,32	green	3
CAN-L	X1:33,34	yellow	2
CAN-GND	X1:35	white	1
Shield	X1:1		

### CAN-BUS connection with several BAMOBIL-D3-IM

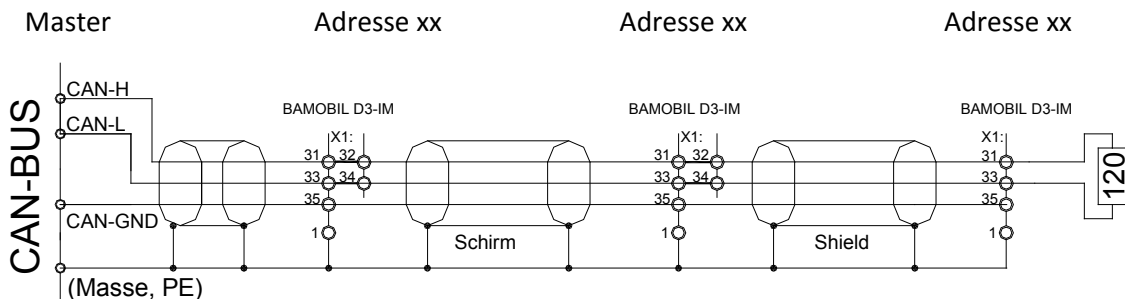

Bamobil-D3-IM-CAN-3x-2

Terminating resistor at the end of the bus line >120 Ohm between the CAN-H and CAN-L.

## 4.13 Resolver connection

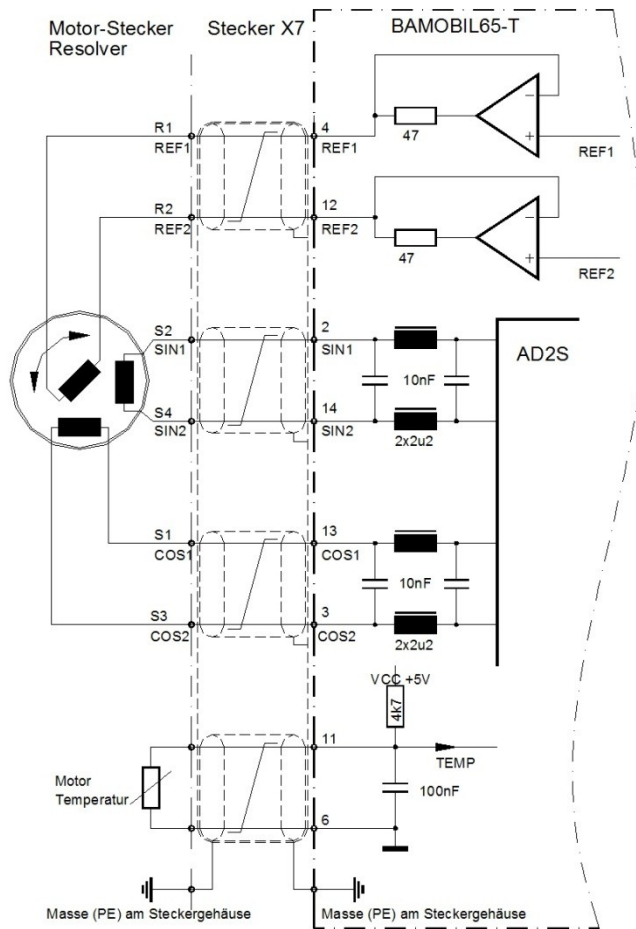

BAC65-T-Reso-1

only for BAMOBIL-D3-RS

The resolver is an absolute measuring system for a motor revolution. It is robust and not impaired by high motor temperatures.

Its build corresponds to a revolving transformer. The rotor is supplied by the reference (10 kHz). The stator supplies the sine and cosine signals modulated by the rotational frequency. The amplitudes of these signals are analyzed and digitalized in the servo-drive. The resolution is automatically set to an optimum of 10, 12, or 14 bit.

The max. possible speed is 50000 (10bit).

The digitalized signals are used for the polar wheel angle, the position and speed control, and the incremental output.

Use only motors with a 2-, 4-, 6-, or 8-pole resolver which have been approved by the manufacturer.

Observe the motor specific connection data sheet (RS)!

<b>Connector</b>	X7	14-pole Tyco connector
<b>Connecting cable</b>	4 x 2 cores, twisted in pairs and shielded, additional overall shield.	
		For link chains use appropriate cables!
<b>Cable length</b>	for >25m only use high-quality resolver cables with adequate shielding properties.	
<b>Shield connection</b>	across connector X7:	combine all shields and connect them to the housing
	across the motor connector:	connect the overall shield to the connector housing
<b>Setting parameters</b>	see software Manual DS	

## 4.14 Encoder TTL connection

Only for BAMOBIL D3-IN

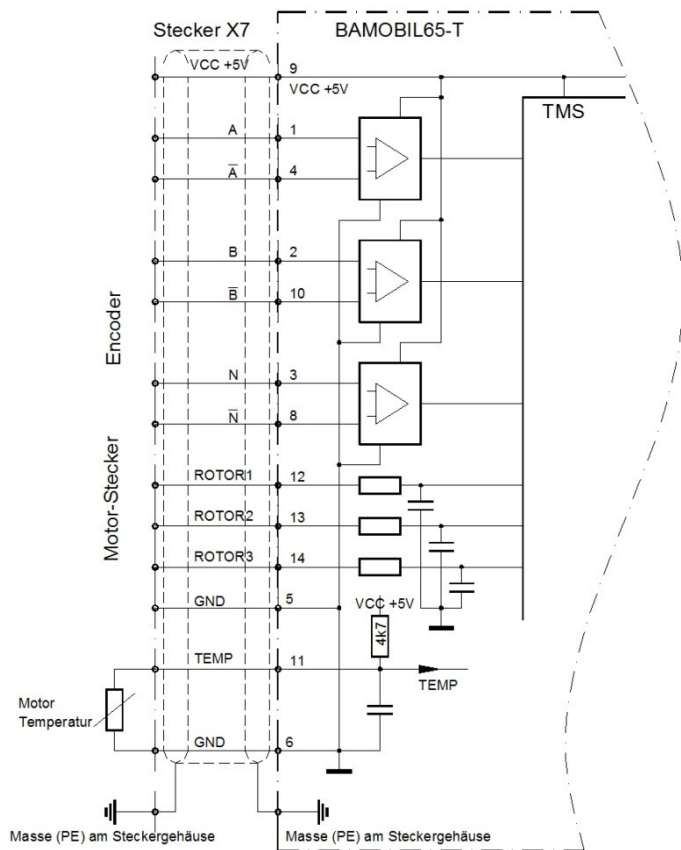

TTL incremental encoder (encoder) with 2 counter tracks and 1 zero track plus 3 rotor position tracks. Counter tracks with or without push-pull output.

(For single connection A, B, N do not connect the negative inputs.)

The counter input corresponds to RS485.

Max. counting frequency 500kHz.

The incremental encoder is galvanically connected with the device zero (GND).

The voltage of 5V is supplied by the servo-drive..

BAC65-T-INC-1

Use only motors with TTL incremental encoders and rotor position tracks which have been approved by the manufacturer.

Observe the motor specific connection data sheet (IN)!

<b>Connector</b>	X7	14-pole D-connector
<b>Connecting cable</b>	10 shielded signal conductors, 2 supply lines	min. cross-section 0.14 mm min. cross-section 0.5 mm
<b>Cable length</b>	For link chains use appropriate cables! for >25m the cross-section of the cable used must be increased by one grade	
<b>Shield connection</b>	across connector X7:  across the motor connector:	connect the shield to the connector housing  connect the shield to the connector housing.
<b>Setting parameter</b>	see software Manual DS	

## Adapter for INC encoder with A,B,N channel without push-pull signals

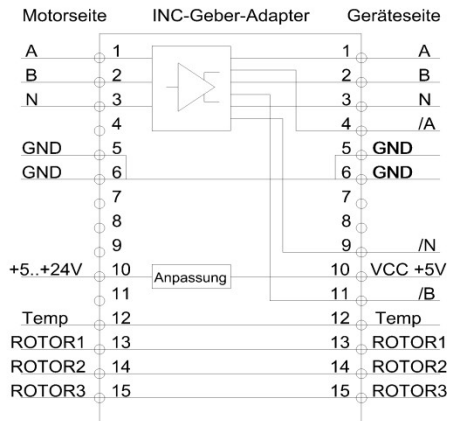

The device input for the incremental counter signals requires the push-pull counter pulses for a reliable detection.

Encoders without push-pull signals (e.g. position encoders) with different supply voltages are used for many simple applications. For these applications the INC adapter must be installed.

The adapter converts the counter signals A, B, N to the push-pull signals A, /A, B, /B, N, /N.

For supply voltages which differ from 5V the voltage must be specified on order and externally be connected.

## Checking the correct connection

### Rotor sequence

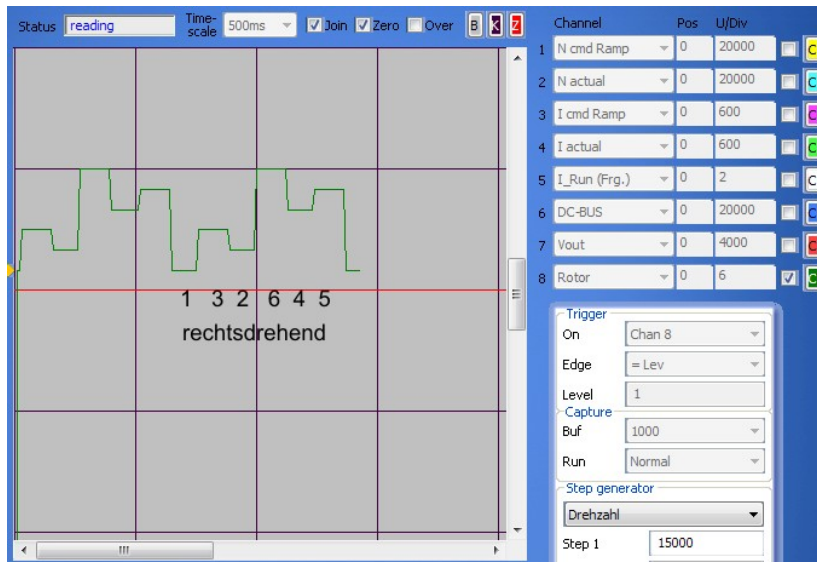

The correct sequence of the rotor signals with a motor turning clockwise is 1,3,2,6,4,5.

If the sequence of numbers is different the encoder connection of the rotor position signals Rotor1, Rotor2, Rotor3 (U,V,W) is not correct.

Use the connection diagram!

### Numerical value

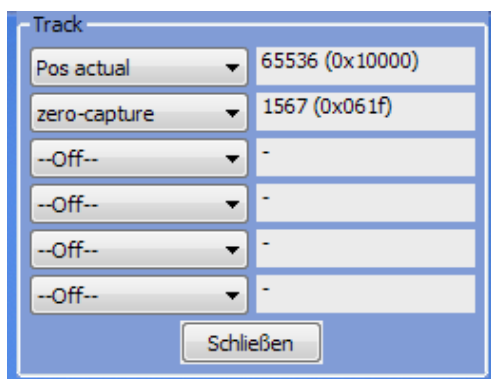

Turn motor clockwise for one revolution without enable.

One motor revolution corresponds to a position value of Num 65536. In case of different results the input of Feedback Inc-Mot (0xa6) is incorrect.

### Zero angle

Motor turning clockwise and anti-clockwise at 10%-100 % speed.

The value of zero-capture must remain constant.

### Encoder error

Fault / feedback (4) / with missing or incorrect rotor position signals.

## 4.15 SIN COS 1Vss connection

Only for BAMOBIL-D3-xx-SC

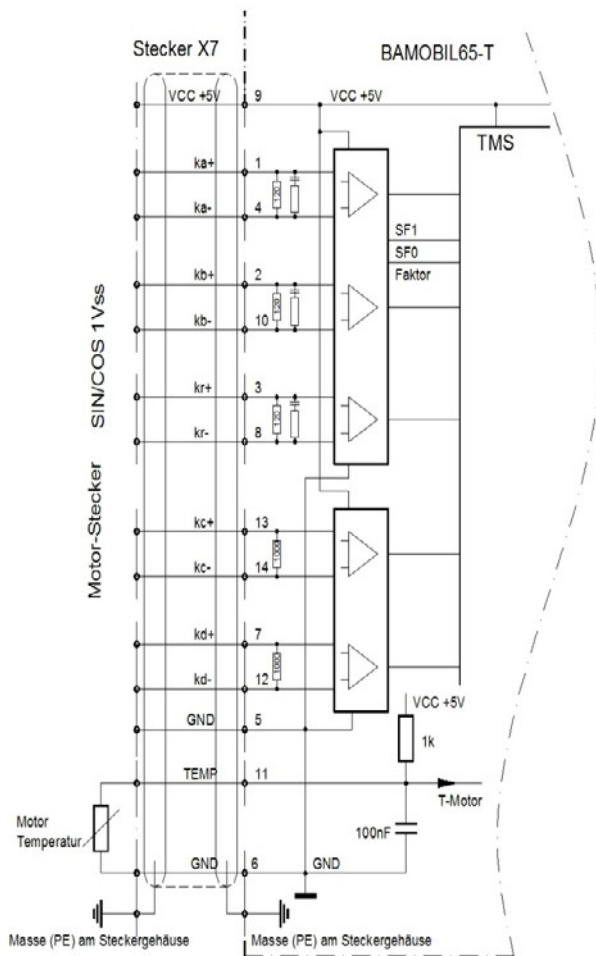

Incremental encoder (encoder) with 2 analog, sinusoidal counter tracks and 1 zero track plus 2 commutating tracks.  
Differential signals 1Vss

Max. counting frequency 500kHz.

The incremental encoder is galvanically connected with the device zero (GND).  
The voltage of 5V is supplied by the servo-drive.

The resolution is automatically set to an optimum.

BAC65-5-SINCOS-1

Use only motors with SIN/COS encoders (SC) which have been approved by the manufacturer.  
Observe the motor specific connection data sheet (SC)!

<b>Connector</b>	X7	14-pole D-connector
<b>Connecting cable</b>	4 x signal conductors, twisted and shielded	min. cross-section 0.14 mm
	2 x signal conductors, shielded,	min. cross-section 0.14 mm
	4 x supply lines, temp.,	min. cross-section 0.5 mm
<b>Cable type</b>	(4x(2x0.14)+(4x0.14)C+4x0.5)C for link chains use appropriate cables!	
<b>Cable length</b>	for >25 m the cross-section of the cable used must be increased by one grade	
<b>Shield connection</b>	across connector X7:	connect the shield to the connector housing
	across the motor connector:	connect the shield to the connector housing.
<b>Setting parameter</b>	see software Manual DS	

Blank page (for printing reason)







## 4.16 Display - State

The state **"normal"** is signalled by a bright green seven-segment display + decimal point (display of the state).

The state **"fault"** is signalled by a bright red fault LED and the seven-segment display indicates the error no.

The state **"warning"** is signalled by the flashing red fault LED and the seven-segment display indicates alternately the state and the warning no.

### Display of the servo-drive states

Anzeige	Point/segment	State	State of NDrive
	flashing	Processor active	
	dark	Auxiliary voltage missing or inherent hardware failure	
	flashing	Starting state after reset (auxil. voltage 24V off-on). The first enable stops the flashing display.	OK = 0
	bright	Drive enable	OK = 1, ENA = 1
	dark	Drive disabled (not enabled)	OK = 1, ENA = 0
	bright	Speed zero (standstill signal)	N0 = 1
	bright	Drive revolves clockwise, N currently positive	N0 = 0
	bright	Drive revolves anti-clockwise, N currently negative	N0 = 0
	flashing	Motor current reduced to continuous current $I_{cns}$	$I_{cns} = 1$
	bright	Motor current at max. current limit $I_{max}$	$I_{cns} = 0$
	dark	Normal operation; Motor current within the current limits	$I_{cns} = 0$
	bright for 0.1 s	Left segment: Right segment:	A new command (value) was received from the BUS or RS232 Digital input change

NDrive:7segment1-8

**Example:** Motor revolving clockwise

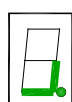

Point flashes = active processor  
 Bottom segment = drive enabled  
 Right segment = motor revolves clockwise

## 4.17 Error displays

The red LED "fault" is bright and the fault no. is indicated by the green seven-segment display.

### List of errors

Display on the BAMOBIL	Error display on the NDrive	Meaning
	NOREPLY-NORS	RS232 failure. Incorrectly connected or missing connecting cable
0	BADPARAS	Defective parameter
1	POWER FAULT	Output stage error
2	RFE FAULT	Faulty safety circuit (only active for RUN)
3	BUS TIMEOUT	Transfer fault BUS
4	FEEDBACK	Faulty encoder signal
5	POWERVOLTAGE	No power supply voltage
6	MOTORTEMP	Motor temperature too high
7	DEVICETEMP	Device temperature too high
8	OVERVOLTAGE	Overvoltage >1.8 x UN
9	I_PEAK	Over-current 300 %
A	RACEAWAY	Racing ( no command value, incorrect polarity)
B	USER	User – error selection
C	I2R	Overload
D	RESERVE	
E	ADC-INT	Current measuring error
F (device-dependent)	BALLAST	Ballast circuit overloaded
Flashing decimal point	Active processor	
Decimal point dark	Auxiliary voltage missing or inherent hardware failure	

### LED displays on the servo

In case of an error the red LED 'fault' lights up and the error no. is indicated.

The BTB (ready) contact is opened.

The software ,BTB message' switches from 1 to 0.

The state message ,RDY' extinguishes.

When the enable is switched off, the error message is still displayed.

The error message deleted:

When the enable is switched on, the function 'cancel errors' is activated via a digital input or a CAN BUS.

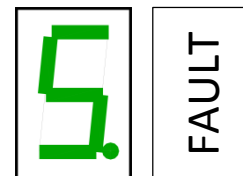

### Note:

When applying the 24V auxiliary voltage with the enable closed (FRG/RUN X1:7 aktiv) the red LED signals an error. There is no fault signal displayed in the 7-segment display.



## 4.18 Warning signals

The state "**warning**" is signalled by the flashing red fault LED and the seven-segment display indicates alternately the state and the warning no.

### List of warning signals

Display on the servo	Warning signal on the NDrive	Meaning	ID-Address
			REGID - 0x8f
0	WARNING_0	No device identification	Bit 16
1	ILLEGAL STATUS	RUN signal	Bit 17
2	WARNING_2	FE signal inactive	Bit 18
3			Bit 19
4			Bit 20
5	POWERVOLTAGE	Power voltage too small or missing	Bit 21
6	MOTORTEMP	Motor temperature >87 %	Bit 22
7	DEVICETEMP	Device temperature > 87%	Bit 23
8	OVERVOLTAGE	Overvoltage >1.5 x UN	Bit 24
9	I_PEAK	Overcurrent 200 %	Bit 25
A			Bit 26
B			Bit 27
C	I2R	Overload >87 %	Bit 28
D			Bit 29
E			Bit 30
F(device-ependent)	BALLAST	Ballast circuit >87 % overloaded	Bit 31



**Fault**

#### Example:

flashing red,  
The display swaps between the state and the warning no.,  
Warning no. 5

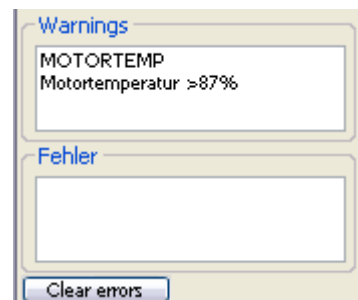

## 4.19 Measured data

(from firmware 378)

### Bus circuit voltage (nom. 48V)

BAMOBL D3-62	Bus circuit voltage	Parameter 0xeb	DC bus - %
Max. voltage	62 V	21961	134
Battery voltage	48 V	17000	103
Overvoltage signal	72 V	25503	155
Charging voltage	56 V	19836	121
without charging voltage	0 V	0	0
Scaling	1	354.22	2.16
DC bus 200%	92 V	32767	200

Parameter 0xeb = 354.22 x bus circuit voltage

### Bus circuit voltage (nom. 96V)

BAMOBIL D3-120	Bus circuit voltage	Parameter 0xeb	DC bus - %
Max. voltage	124 V	21961	134
Battery voltage	96 V	17000	103
Overvoltage signal	144 V	25503	155
Charging voltage	112 V	19836	121
without charging voltage	0 V	0	0
Scaling	1	177,11	1,08
DC bus 200%	185 V	32767	200

Parameter 0xeb = 177.11 x bus circuit voltage

### Current actual value

BAMOBIL-D3	I 100 %	Calibration rated current			Peak current	
		I-device			DC blocked	
Max. value +/- 11Bit	mV	Num	Aeff	A=	Num	A=
x-100	700	560	50	60	800	100
x-120	840	670	60	84	970	120
x-200						
x-250	874	700	125	175	1010	250
x-300	610	490	175	245	710	350
x-450	785	630	225	315	910	450

The basic set-up is protected in the set of parameters.

## 4.20 Output stage temperature

IGBT module temperature	Analog voltage X4 Pin6	Parameter 0x4a
Maximal +80 °C	2.49 V	25819 (FW>378)

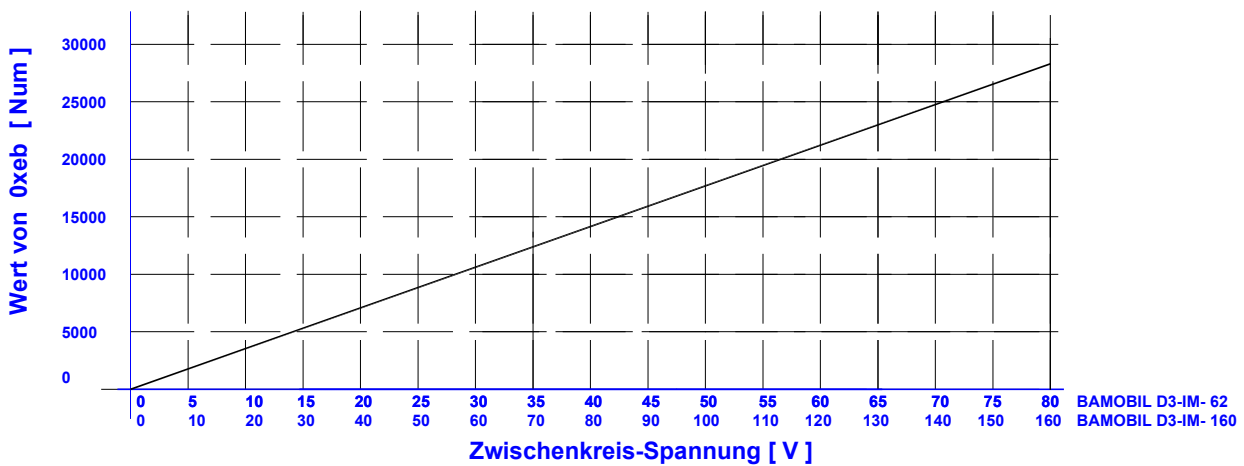
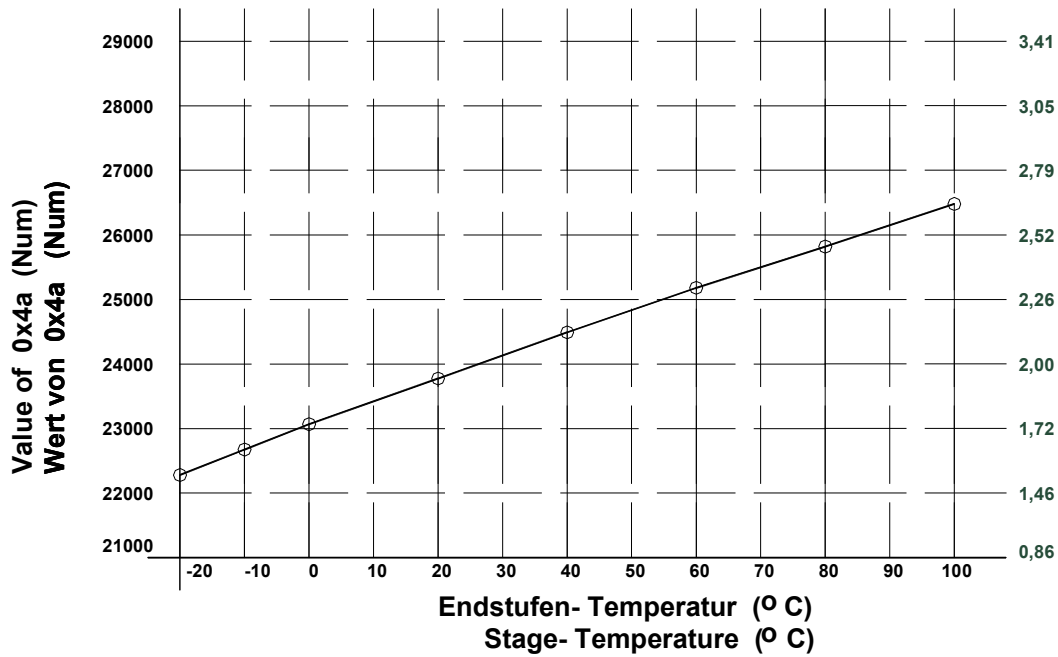

## 5 Warranty

### 5.1 Warranty

**Stegmaier-Haupt** warranties that the device is free from material and production defects. Test results are recorded and archived with the serial number.

The warranty time begins from the time the device is shipped, and lasts two years.

**Stegmaier-Haupt** undertakes no warranties for devices which have been modified for special applications.

During the warranty period, **Stegmaier-Haupt** will, at its option, either repair or replace products that prove to be defective, this includes guaranteed functional attributes. **Stegmaier-Haupt** specifically disclaims the implied warranties or merchantability and fitness for a particular purpose. For warranty service or repair, this product must be returned to a service facility designated by **Stegmaier-Haupt**.

For products returned to **Stegmaier-Haupt** for warranty service, the buyer shall prepay shipping charges to **Stegmaier-Haupt** shall pay shipping charges to return the product to the buyer.

However, the buyer shall pay all shipping charges, duties and taxes for products returned to **Stegmaier-Haupt** from another country.

The foregoing warranty shall not apply to defects resulting from:

- improper or inadequate repairs effected by the buyer or a third party,
- non-observance of the manual which is included in all consignments,
- non-observance of the electrical standards and regulations,
- improper maintenance
- acts of nature.

All further claims on transformation, diminution and replacement of any kind of damage, especially damage, which does not affect the **Stegmaier-Haupt** device, cannot be considered. Follow-on damage within the machine or system, which may arise due to malfunction or defect in the device cannot be claimed. This limitation does not affect the product liability laws as applied in the place of manufacture (i.e. Germany).

**Stegmaier-Haupt** reserves the right to change any information included this MANUAL.

All connection circuitry described is meant for general information purposes and is not mandatory.

The local legal regulations, and those of the standards authorities have to be adhered to. **Stegmaier-Haupt** does not assume any liability, expressively or inherently, for the information contained in this MANUAL, for the functioning of the device or its suitability for any specific application.

#### **All rights are reserved.**

Copying, modifying and translations lie outside **Stegmaier-Haupt's** liability and thus are not prohibited.

**Stegmaier-Haupt's** products are not authorised for use as critical components in the life support devices or systems without express written approval.

The onus is on the reader to verify that the information here is current