

# MANUAL

## Thyristor - Drive

1 Quadranten

Classic P3

60 ... 150 A

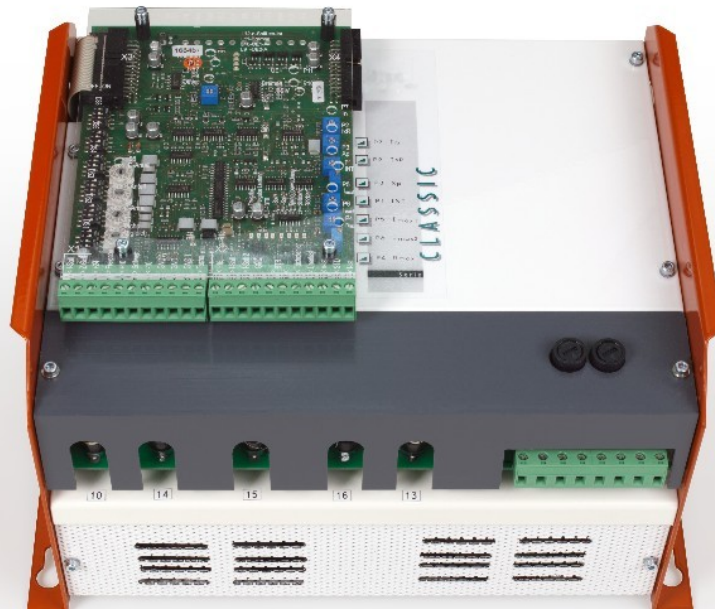

Stegmaier-Haupt GmbH  
Industrieelektronik-Servoantriebstechnik  
Untere Röte 5  
D-69231 Rauenberg  
Tel.: 06222-61021  
Fax: 06222-64988  
Email: [info@stegmaier-haupt.de](mailto:info@stegmaier-haupt.de)  
Http: // [www.stegmaier-haupt.de](http://www.stegmaier-haupt.de)

Issue / Revision

01/2018 V 01

<b>1</b>	<b>Contents</b>	
<b>2</b>	<b>Basic Information</b> .....	<b>2</b>
2.1	Safety advice .....	2
2.2	Standards and guidelines: .....	2
2.3	General and features .....	4
2.4	Technical data .....	5
2.5	Specification .....	6
2.6	Interfaces .....	6
<b>3</b>	<b>Mechanical Installation</b> .....	<b>7</b>
3.1	Dimension .....	7
3.2	Dimension .....	8
<b>4</b>	<b>Electrical installation</b> .....	<b>9</b>
4.1	Connection .....	9
4.2	Connection diagram .....	11
4.3	CE-Advices .....	12
4.4	Motor connection .....	13
4.5	Actual value connection .....	14
<b>5</b>	<b>Adjustment</b> .....	<b>16</b>
5.1	Current controller.....	16
5.2	Circuit diagram .....	17
5.3	Displays.....	18
<b>6</b>	<b>Commissioning</b> .....	<b>19</b>
6.1	Commissioning .....	19
6.2	Protocol (Commissioning) .....	21
<b>7</b>	<b>Faults</b> .....	<b>23</b>
7.1	Error diagnosis .....	23
<b>8</b>	<b>Warranty</b> .....	<b>24</b>

## 2 Basic Information

### 2.1 Safety advice

Electronic equipment is not fault proof.

**Attention – High voltage  
AC 530V~ / DC 450-550V=  
Shock hazard / Danger of life!!**



Before installation or commissioning begins, this manual must be thoroughly read and understood by the technical staff involved.  
The devices are electrical equipment (EB) to the power electronics for the control of power flow in electrical power systems.  
**Protection rating IP00.**

**Control and power connections can  
voltage lead, works without the drive!**

**Measured before disassembly voltage!**



### 2.2 Standards and guidelines:

The device and its associated components can only be installed and switched on where the local regulations and technical standards have been strictly adhered to:

EU Guidelines:	2004/108/EG, 2006/95/EG, 2006/42/EG EN 60204-1, EN292, EN50178, EN60439-1, EN61800-3, ECE-R100
IEC/UL:	ISO 6469, ISO 26262, ISO 16750, ISO 20653, ISO12100 IEC 61508, IEC364, IEC664, UL508C, UL840
VDE Regulations:	VDE100, VDE110, VDE160
Trade body guidelines:	VGB4

## The user must ensure that in the event of:

- device failure
- incorrect operation
- loss of regulation or control

the axis will be safely de-activated.

It must be ensured that the machines, equipment or vehicles are fitted with device independent monitoring and safety feature.

Non-earthed systems (e.g. vehicles) must be protected by means of independent isolation watchdog.

There must be no danger to persons and property any time!



### Assembly

- should only be carried out when all voltages have been removed and the units are secured
- should only be carried out by suitably trained personnel

### Installation

- should only be carried out when all voltages have been removed and the units are secured
- should only be carried out by suitably trained personnel for electricians
- should only be carried in accordance with health and safety guidelines

### Adjustments and programming

- should only be carried out by suitable trained personnel with knowledge in electronic drives and their software
- should only be carried out in accordance with the programming advice
- should only be carried in accordance with health and safety guidelines

### CE

When mounting the units into machines and installations the proper operating of the units may not be started until it is ensured that the machine, the installation, or the vehicle comply with the regulations of the EC machinery directive 2006/42/EG and the EMC guideline 2004/108/EG.

On the installation and test conditions described in the chapter CE-advice it is adhered to the EC guideline 2004/108/EG including the EMC standards EN61000-2 and EN61000-4.

A manufacturer's declaration can be requested.

The manufacturer of the machine or installation is responsible for observing the threshold values demanded by the EMC laws.

### QS

The devices are archived with serial number and the test data from the manufacturer for 5 years. The test reports may be requested.

## 2.3 General and features

**This manual describes the basic unit and is only in connection with the manual of the control electronics (e.g. REGxx) valid.**



### **Manual use in connection with:**

- an analogue control                    **REGxx**
- options                                    **Multi-xx**

### **Build**

- switch cabinet mounting a
- according to the VDE, DIN and EU regulations
- standard control electronics REG
- intrinsically safe power section with current control loop
- devices are touch-safe cover
- uncontrolled field supply unit
- optional units

### **Galvanic isolation between**

- the power section and the housing
- the power section and the control electronics

The distance of air gaps and leakage paths adhere to the VDE standards (>8mm).

### **Components**

- fully insulated thyristor modules, comfortably over-dimensioned
- only components customary in trade and industrially standardized are used
- LED displays
- precision potentiometers for fine adjustments
- plug-in jumpers for the system set-up

### **Characteristics**

- ▣ Series Classic P3
- ▣ Thyristor drive for dc motors
- ▣ Power range 27 kW to 82,5 kW
- ▣ DC-motors in 1 or 2 quadrant mode of operation with an invariant direction of the moment (crane operation)
- ▣ Energy recovery
- ▣ Fast analogue current control
- ▣ Temperature watchdog-power section
- ▣ Completely controlled three-phase bridge circuit
- ▣ Uncontrolled field rectifier
- ▣ 26-in interface
- ▣ Features of the control electronics
- ▣ see MANUAL REGxx or third-party product documentation
- ▣ Optional units

# Basic Information

## 2.4 Technical data

### P3 400/450-x

Power connection 360 ... 440V~  
 Auxiliary voltage connection 360 ... 440V~ or 200 ... 250V~  
 Max. output voltage. +450V=

P3 400/450-			60	120	150
Input current		A~	48	96	120
Output current	peak	A=	120	240	300
	continuous	A=	60	120	150
El. power		kW	27	54	67,5
Fuses (fast acting)	input	A	63	125	160
Power choke (1 pc. per controller)		mH	KD3-75 0.3	KD4-100 0.25	KD4-150 0.16
Armature choke		Type	UI150B-75	UI180B-150	UI180B-150
		mH	5.5	4.2	4.2
Armature chokes are necessary only for special applications.					
Cooling			self cooling	fan	fan
Dimensions	wxhxd	mm	290x210x170	290x210x170	290x210x170

### P3 500/550-x

Power connection 500 ... 550V~  
 Auxiliary voltage connection 360 ... 440V~  
 Max. output voltage. +550V=

P3 500/550-			60	120	150
Input current		A~	48	96	120
Output current	peak	A=	120	240	300
	continuous	A=	60	120	150
El. power		kW	33	66	82,5
Fuses (fast acting)	input	A	63	125	160
Power choke (1 pc. per controller)		mH	KD3-75 0.3	KD4-100 0.25	KD4-150 0.16
Armature choke		Type	UI150B-75	UI180B-150	UI180B-150
		mH	5.5	4.2	4.2
Armature chokes are necessary only for special applications.					
Cooling			self-cooling	fan	fan
Dimensions	wxhxd	mm	290x210x170	290x210x170	290x210x170

# Basic Information

## 2.5 Specification

<b>Mains frequenca</b>	50 or 60 Hz $\pm 5\%$
Protection rating	IP 00
Format	VDE 0100 group C VDE 0160
Humidity rating	class F acc. to DIN 40040
Site of installtion	< 1000m above sea level
Operating temperature range	0 ... 45°
Extended operating range	up to 60°C reduced by 2%/°C
Storage temperature range	-30°C to +80°C
<b>Amplification</b>	
Input signal	0 ... +10 Volt =
Output	0 ... +200% type current
Enable	>+10 Volt
<b>Current control loop circuit</b>	
Control precision	$\pm 2\%$
Control range	1 : 50
<b>Speed control loop circuit with REG</b>	
Control precision (without actual value error)	$\pm 0,1 \%$
Control range	1 : 300

## 2.6 Interfaces

<b>Function</b>		<b>Connector no.</b>
+ 24Volt	$\pm 10 \%$	X3: 1 and 2
+ 15Volt	$\pm 2 \%$	X3: 3 and 4
-24 Volt	$\pm 10 \%$	X3: 5 and 6
-15 Volt	$\pm 2 \%$	X3: 7 and 8
Device zero GND	0	X3: 9,10,11,12,13 and 14
I – command value (GND)	0	X3: 15
I – command value (signal)	+ 10 V=	X3: 16
Current controller enable	+ 10 V=	X3: 17
Drive disable 1	+ 10 V =	X3: 18
Drive disable 2	+ 10 V=	X3: 19
n (speed) actual	+ 10 V=	X3: 20
I (current) actual	+ 10 V=	X3: 21
Over-current power section	n. B.	X3: 22
Ignition angle 1	+ 10 V=	X3: 23
Ignition angle 2	+ 10 V=	X3: 24
Drive ready BTB	+ 10 V=	X3: 25
Not assigned	n/a	X3: 26

# Mechanical Installation

Dimension

## 3 Mechanical Installation

### 3.1 Dimension

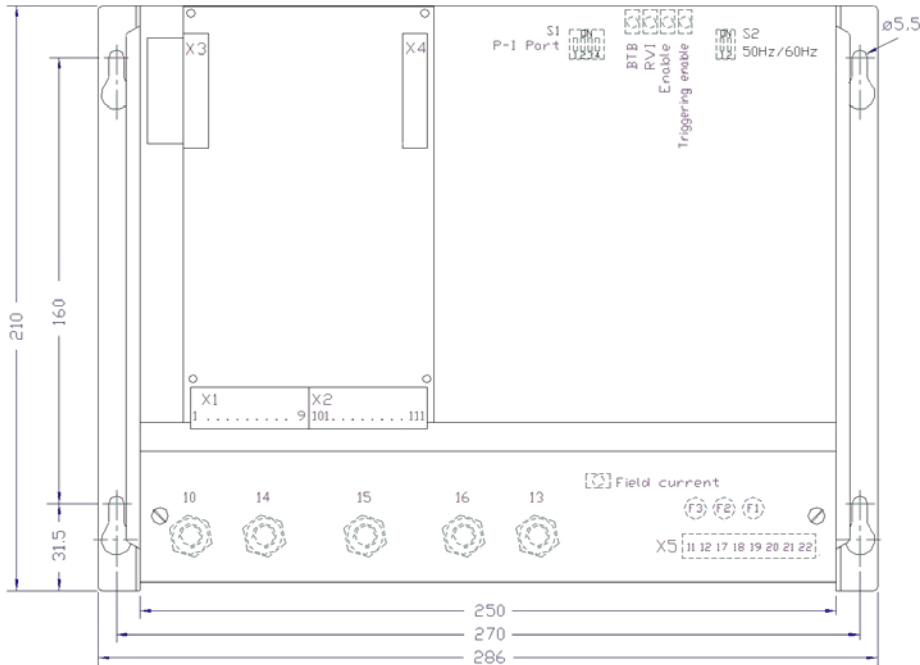

Manuals-Zeichnungen-P3-M1352-1

#### Adjustments

Switch S1                      PI loop circuit                      Current control loop RVI

#### LED displays:

Enable			
Current control loop	enable	green	enabled
Triggerring	enable Z	green	enabled
Current command value			
Current control loop RVI	RVI	green	control active
The luminous intensity depends on the trigger angle.			
Drive ready	BTB	green	ready
Correct field current	field current	green	flowing field current

#### Jumper

60 Hz adjustment                      Switch S2-1                      ON



# Mechanical Installation

## 3.2 Dimension

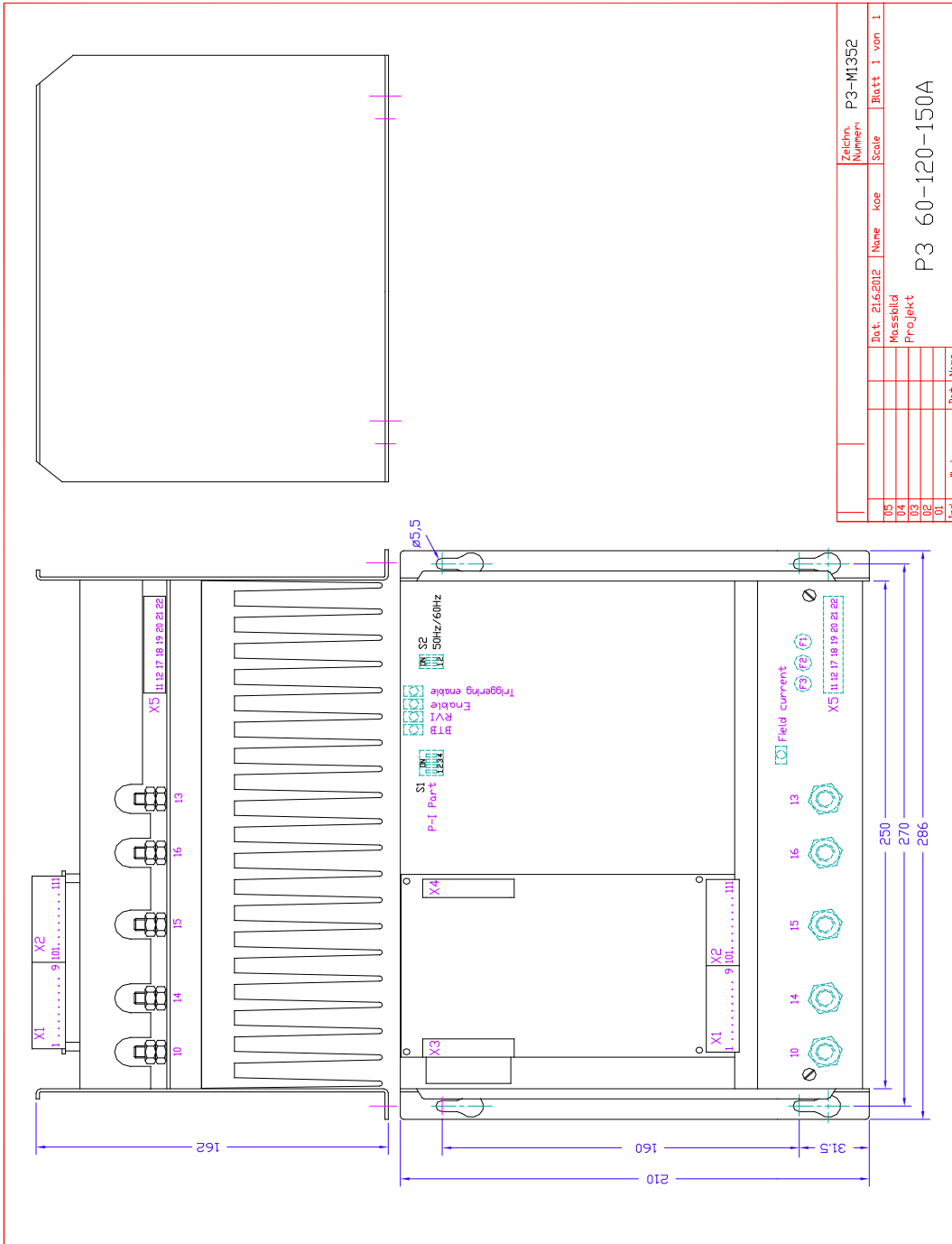

Manuals-Zeichnungen-E-P3-M1352

Dimension

## 4 Electrical installation

### 4.1 Connection

#### Auxiliary supply and field connections

The order of the connections to the screw terminals is obligatory.

The input and output conductors may be altered or supplemented in accordance with the electrical standards. All further advice is non-obligatory.

The controllers are delivered with an auxiliary voltage input for 230 or 400V~

**(Please observe the type plate)**

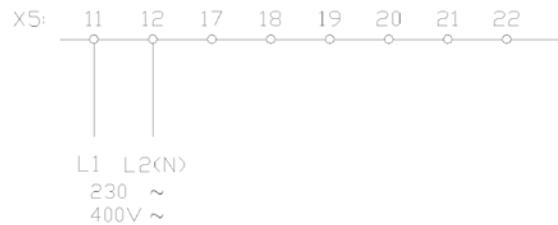

Current consumption: 0.1A

Fuse F1 0.8A (5x20)

Manuels-Zeichnungen-P3-A054-Hilfssp.

The auxiliary voltage and the field supply are both connected across the plug-in terminal X5.

The phase position of the auxiliary voltage and the power supply voltage do not have to correspond to each other.

The field voltage amounts to 210V= with a 230V~ connection and to 360V= with a 400V~ connection.

Max. field current: 10A

Feld fuse –F2, -F3 10AF (6.3 x 32)

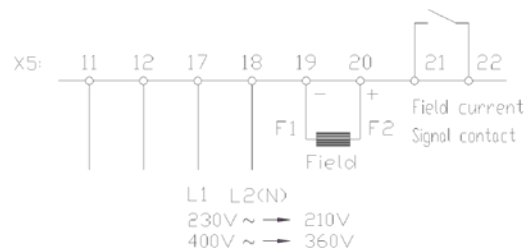

Manuels-Zeichnungen-P3-A054-Feld

The field current has a watchdog. In case of a field failure the signal contact for the field current opens.

Contact for 24V / 1A

The LED for the field current lights when field current flows.

# Electrical installation

## Power connections directly to the mains power supply or via a transformer

The power connections must be protected by means of fast acting fuses.

The power choke inductance must be  $>80 \times H$ .

The phases of the power connection and the auxiliary voltage do not have to be equal.

There is an internal watchdog for the power connection. If the power supply or the fuses fail, the device switches off and the BTB contact opens.

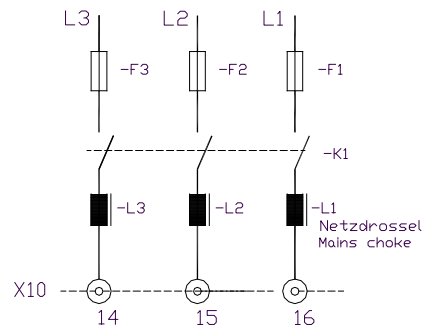

Manuels-Zeichnungen-P3-A054-Netz

L1, L2, L3 right rotating field

An auto-transformer can be used.

For motors with a weak voltage steadiness isolating transformers must be used.

The transformer performance is determined by the permanent current and the secondary voltage.

Fast acting fuses must be installed between the transformer and the control unit.

If the secondary voltages produced by the transformer are inferior to 60% of the device type voltage, the voltage watchdog has to be adapted.

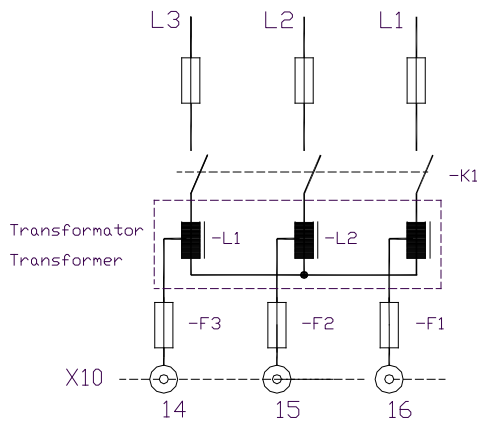

Manuels-Zeichnungen-P3-A054-Trafo

These fuses are monitored for drop-out by the power supply watchdog.

The phases of the secondary voltage of the transformer and the auxiliary voltage do not have to be equal.

It has to be ensured that the contacts of the contactors on the input side of the transformer are sufficiently rated for the switch-on current of the transformer. The transformer has to be protected by means of slow acting fuses.

### 4.2 Connection diagram

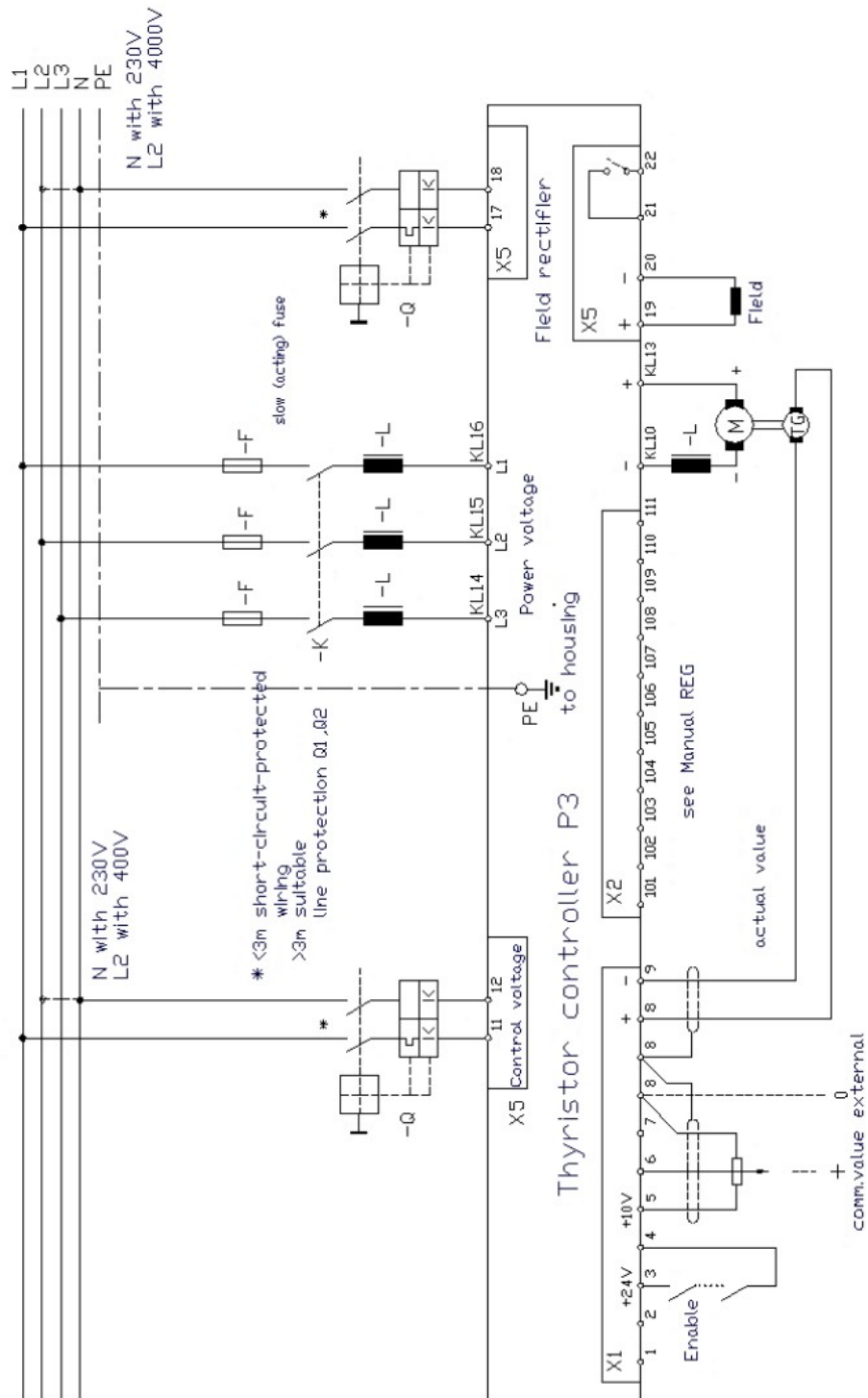

Manuels-Zeichnungen-E-P3-A021

# Electrical installation

## 4.3 CE-Advices

The devices adhere to the EU guidelines 89/336/EWG and the technical standards EN 61000-2 and 61000-4 provided that the following conditions are observed:

The device, the power choke, and the filter capacitors are mounted on a 500x500x2 mm mounting plate.

The mounting plate must be connected to ground using a 10mm<sup>2</sup> wire.

The motor housing must be connected to ground using a 10mm<sup>2</sup> wire.

The device ground X1:8 must be connected to the mounting plate using a 2.5mm<sup>2</sup> wire.

Device PE screw must be connected to the mounting plate using a 4mm<sup>2</sup> wire, l = 50mm.

### Connection:

Power choke type: see technical details

Filter capacitors: 3 x 0.5µF/600V~      3 x 1µF (x) + 1 x 0.5µF (y)

Conductor length between the device and the power choke <250mm

### Motor connection:

Motor conductors      l = 1.5m, shielded

Tacho and all control lines      l = 1.5m, shielded

Shielding connected to PE

### Assembly plan

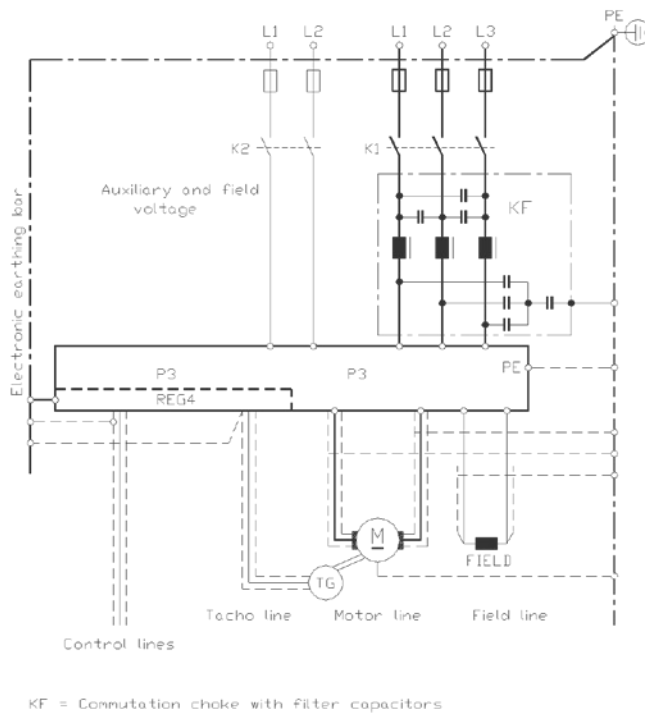

## 4.4 Motor connection

Armature chokes are necessary only for a few applications, e.g. quiet motor operation (stage technique).

The motor is connected to the terminals 10 and 13 via an armature choke.

Min. armature choke inductance:

$$-L \text{ [mH]} = U_A / I_A \times 0.8$$

(Motor voltage divided by armature voltage. times 0.8):

The motor lines should only be switched during a current-free state. Switching off under current will create arcing across the switch contacts. Switching on while the drive is enabled will cause the fuse to fail. RNB resistors (brake resistors in case of power supply failure) are to be connected in parallel directly to the motor armature without isolating the motor from the control unit.

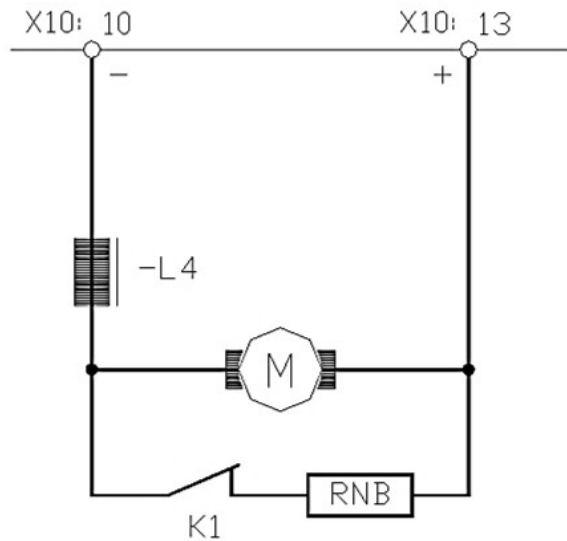

Zeichnungen-P3/P3-Motor-V647.1

At the output of the armature choke the motor line is protected against short-circuits.

Conductor cross-section (min.)				
Type current	A	60	120	150
Mains power supply	mm <sup>2</sup>	6	16	25
Motor connection	mm <sup>2</sup>	10	25	35

The conductor cross-sections must be rated for continuous motor current.

The power lines and motor lines are to be routed separately from sensitive measuring and control lines.

Compared to transistor chopper amplifiers the thyristor servo drives have little electro-magnetic and electro-static interferences which can easily be filtered.

## 4.5 Actual value connection

The actual value is connected to the control electronics (e.g. REG) as tacho signal or as armature voltage signal.

The quality of the actual value signal determines the control range and the control accuracy. Best results can be achieved through the use of dc tacho generators.

Three-phase tacho generators with rotor position evaluation or digital actual value encoders as well as ac or three-phase tachos with rectification are suitable for 1 quadrant operation. Tacho lines should be properly shielded and routed separately from power lines. Shield to be connected to the device.

Please observe the tacho adjustment instructions described in the manual for the control electronics (e.g. REG).

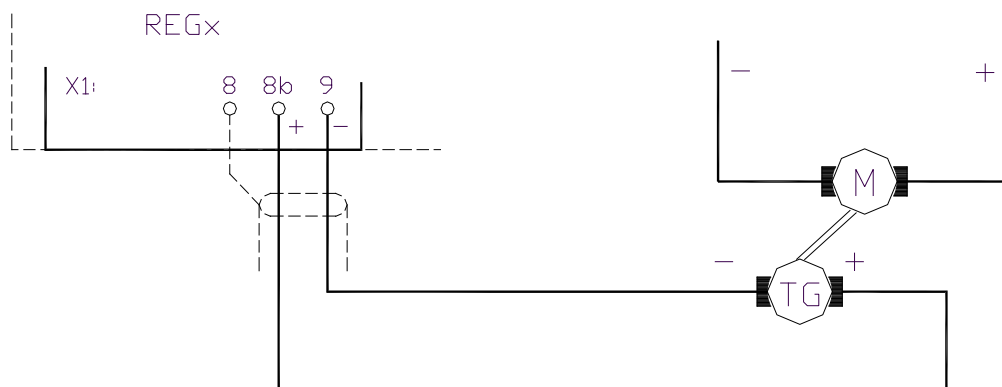

Manuels-Zeichnungen-P3-A054-Tachoreg.

# Electrical installation

For 1 quadrant controls with small control ranges (up to 1:50) and little demands on accuracy and dynamic the armature voltage can be used as actual value signal.

The actual value lines must be protected by two fuses of 0.1A/500V installed directly in the armature voltage.

For armature voltages superior to 180V two additional drop resistors must be pre-connected, thus, the module EXZU-UA (additional equipment) can be used. It contains two fuses and two resistors in an insulated housing.

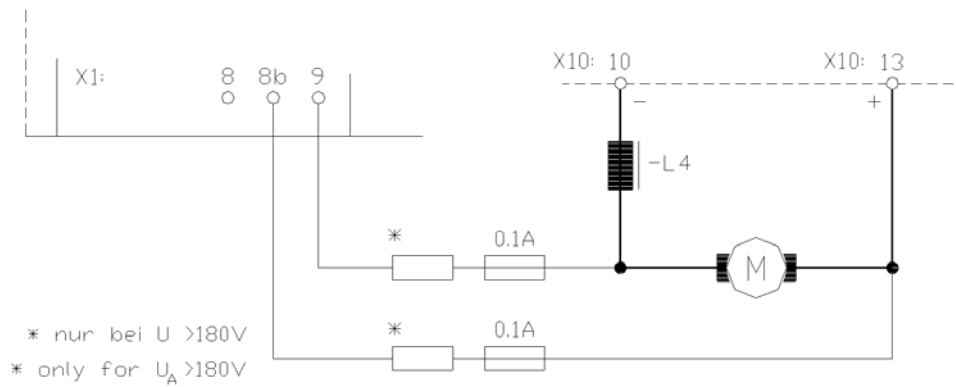

P3-A054-Ankerreg



# Adjustment

## 5 Adjustment

### 5.1 Current controller

The current control characteristics of the power sections can be adjusted. The PI characteristics of the controller RVI is adjusted by the 4-position DIP switch S1.

#### Switch position

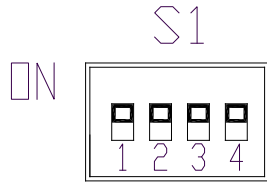

Manuels-Zeichnungen-P3-A054-S1

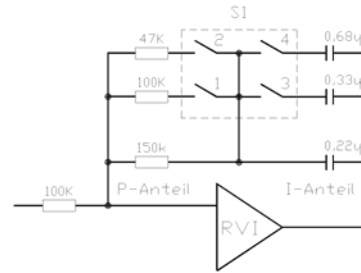

Manuels-Zeichnungen-P3-A054-RVI

All switches are closed on delivery of the devices. This corresponds to the position for the lowest armature circuit inductance.

For a higher inductance the proportional amplification can be changed via the contacts 1 and 2 and the integral time constant can be changed via the contacts 3 and 4.

### Oscilloscope - current adjustment

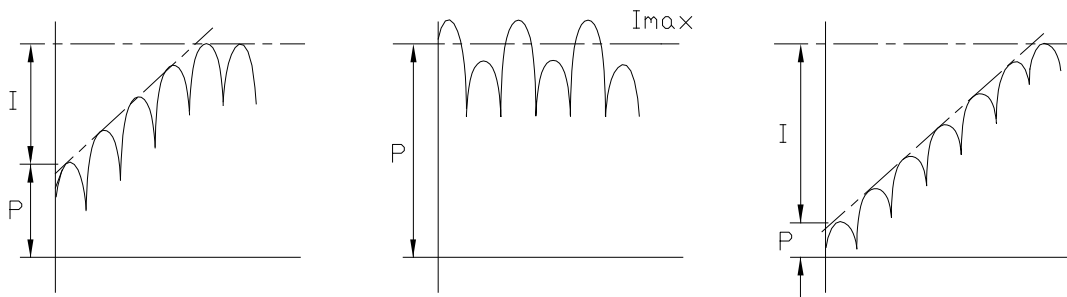

Manuels-Zeichnungen-P3-V161

setting optimal

P-gain is too large

P-gain is too small

For 60Hz operation the switch S2/contact 1 must be at position 'ON'.

Some important functions are indicated by LEDs:

These are drive ready (BTB), current controller enable (RVI), triggering enable (Z), current controller output (RVI)

The green LEDs indicate the active states.

# Adjustment

## 5.2 Circuit diagram

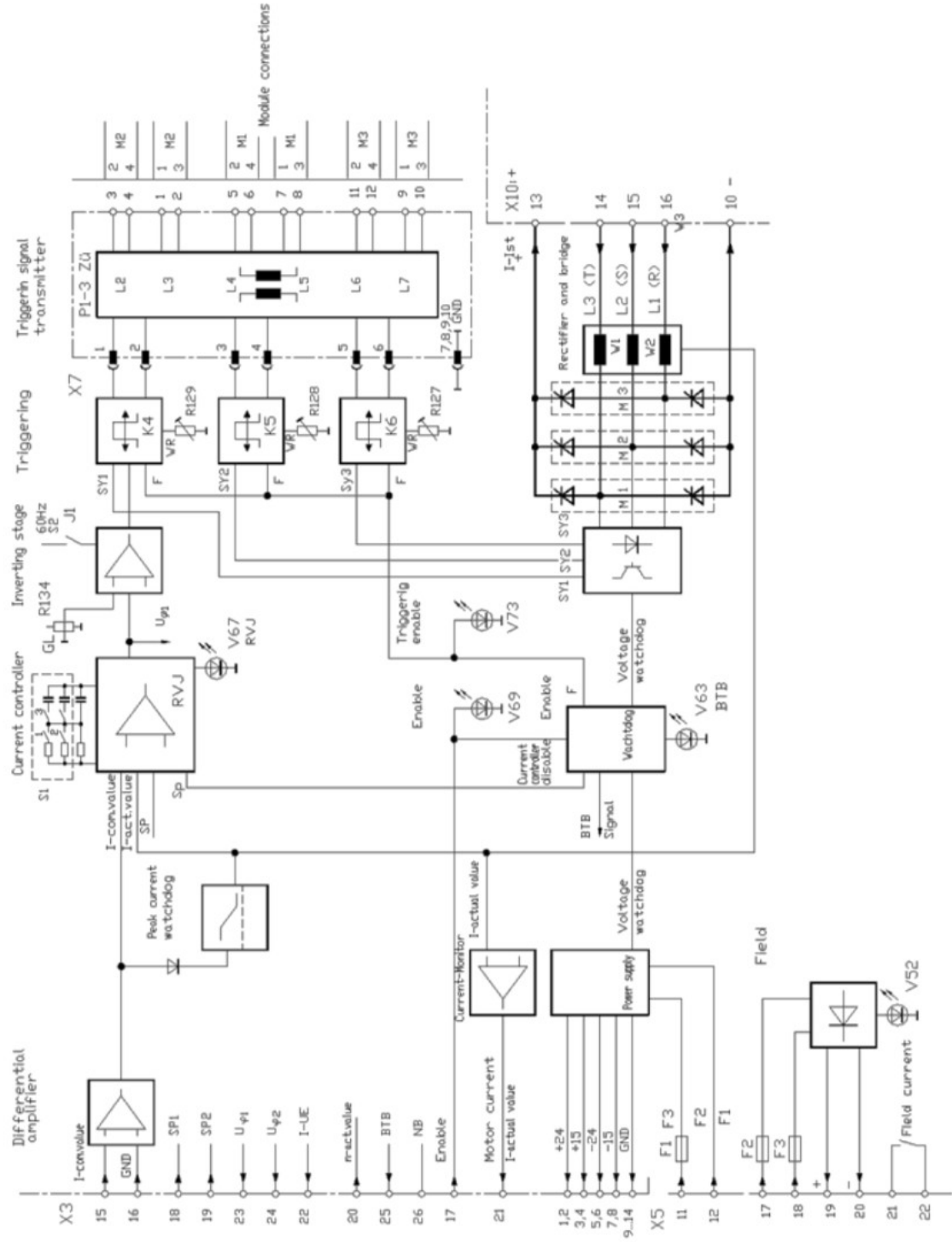

Manuels-Zeichnungen-E-P3-S074-1

## 5.3 Displays

The thyristor power sections have an internal watchdog.

If there are no errors the BTB signal provides a voltage of  $>+10V$ .

The BTB relay on the control electronics is triggered via the test output X3:25.

The BTB signal voltage is  $<2V$  if the following errors occur:

Auxiliary voltage: +24V, +15V, -15V

Power supply: fuse failure, connection sequence, under-voltage

In case of errors or failure the power section is immediately internally disabled without delay.

The current and the voltage can be measured in the load circuit (motor circuit) by means of multimeters.

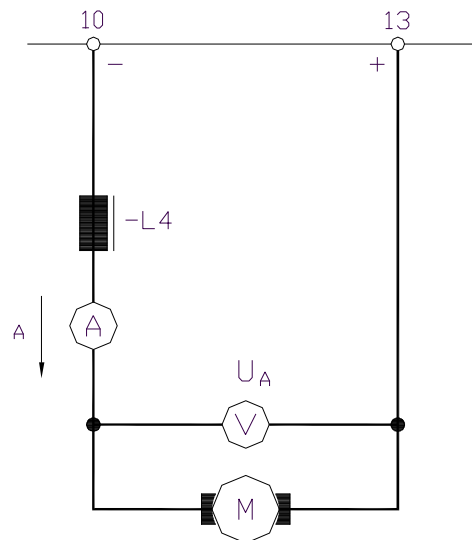

Manuels-Zeichnungen-P3-A054-Motor-Mess

The dc current can be measured by means of measuring instruments which indicate mean values or by instruments which indicate actual values. When measuring the dc current with these different measuring instruments there will be measuring errors which are determined by the form factor. For rated device current and the correct motor chokes the actual value is 1 to 5% higher than the mean value.

The motor voltage is measured as dc voltage.

The max. dc voltage must not be superior to  $1.12 \times$  power supply.

If the speed command value (X1:6 (REG)) or the current command value (X3:16 or X4:15) are positive, the voltage across terminal 10 is negative against the terminal 13.

The signals of the current and the speed can be measured across the terminals X2:109 and X2:111 of the control electronics REG

The measured speed value across terminal X2:109 is -5V at +100% speed.

The measured current value across terminal X2:111 is +5V at +200% type current.

## 6 Commissioning

### 6.1 Commissioning

Connect the drive in accordance with the P3 manual and the control electronics manual (e.g. REG).

#### Please observe in particular:

Check the power supply voltage with that specified on the type plate

Insert the correct fuses according to the technical data (see contents).

Check the field voltage connection and the motor and tacho connections!!!

For 60Hz applications adjust the switch S2, contact 1 to position 'ON'.

#### Commissioning

Basic connections: Mains supply, field, tacho, or armature feedback, drive enable, command value.

For armature voltage control the tacho watchdog must be switched off.

#### Drive enable switch

open or drive enable voltage 0V/command value voltage 0V

Adjust switch S9 to tacho voltage, adjust to 0 for armature voltage control.

Adjust switch S4 to position 2, switch S5 to position 6.

Adjust the potentiometer  $I_{max1}$  to left full scale

Adjust the potentiometer  $I_{max2}$  to approx. 10%.

Potentiometer	Xp	to 50%
Potentiometer	ID	= 100 %
Potentiometer	IxR	= left full scale
Potentiometer	$n_{max}$	= left full scale
Potentiometer	INT	= left full scale
DS1:K1, DS2:K4	ON	
Bridges R13 and R14 soldered-in (only tacho)		

#### Apply the voltage

The LED L3 (BTB) and the LED L7 (standstill) must light. All other LEDs are off.

Close the switch 'drive enable' or apply a drive enable voltage of >10V

The LEDs L1 and L2 must also light. The drive must be at a standstill or turn slowly (offset

If the drive accelerates in the correct direction, the polarity of the tacho voltage and the armature voltage feedback must be changed.

If the drive accelerates in the wrong direction, the polarity of the armature or the field must be changed.

#### Command value voltage

Increase the command value voltage to 10 %. The drive must accelerate to approx. 10% of the speed. If the rotation direction is wrong, change the polarity of the tacho and the field **or** the polarity of the tacho and the armature.

## Current controller

(Switch S1 on the power section)

The current amplification is adjusted to a low armature circuit inductance (all switches "On")  
High inductance values can lead to motor oscillation which cannot be influenced by means of the speed controller. In this case, first set switch S1-2 to "Off". If the drive still does not run smoothly, set the switch S1-1 to "Off".

The current controller response can be measured by means of an oscilloscope across the test point X4:20 (see chapter 5.0).

## Speed controller amplification

Adjust on the REG board.

Adjust the P-term to the lowest possible setting from 1 to 5 (switch S4).

Adjust the I-term according to the centrifugal mass (switch S5):

large centrifugal mass - high adjusted value

small centrifugal mass - low adjusted value

With the command value set to 10% speed, increase the amplification by turning the potentiometer Xp clockwise. When the drive begins to oscillate, reduce the amplification by turning the potentiometer anti-clockwise by approximately 10%.

For the fine adjustment of the amplification the control response should be measured by means of an oscilloscope across the test point X4:15

## Further adjustments

such as speed, peak current, continuous current, etc. (rf. to the manual REG)

## Switching off

If the switch 'drive enable' is opened, or the drive enable voltage is switched to 0V, LED L1 and L2 will extinguish and the drive decelerates.

After approx. 2s the thyristor triggering circuit is disabled

## Commissioning adjustments

The adjustments should be documented in the protocol and the adjustment potentiometers should be sealed with a suitable lacquer.

# Commissioning

## 6.2 Protocol (Commissioning)

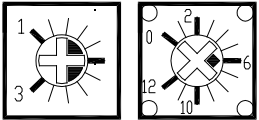
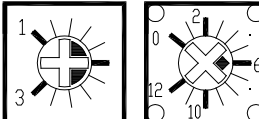
<b>Customer</b>				<b>Machine No. I</b>				
<b>Device</b>				<b>Series No.</b>				
<b>Control voltage</b>		[V~]						
<b>Power voltage</b>		[V~]						
<b>Field voltage</b>		[V=]						
<b>Input REGxx</b>								
Enable	Contact ?	Voltage [V=]						
Nominal value	Type	Voltage [V=]						
Auxiliary nom. value	Type	Voltage [V=]						
Current nom. value	I <sub>max1</sub> extern	Voltage [V=]		<b>no function</b>				
Current nom. value	I <sub>max2</sub> extern	Voltage [V=]						
<b>Speed controll settings REGxx</b>								
<b>Switches</b>								
Tacho-adjustment		S9	Position	 REG5 - Schotax 1				
P-term		S4	Position					
I-term		S5	Position					
D-term		S8	Position					
<b>Poti-Stellungen</b>								
Speed	n <sub>max</sub>	P4	Position	 REG5 - Poti 1				
Peak current	I <sub>max1</sub>	P5	Position					<b>no function</b>
Peak current	I <sub>max2</sub>	P6	Position					
Continuous current	I <sub>D</sub>	P7	Position					
Integrator	INT	P1	Position	 REG5 - Poti 2				
Amplification	X <sub>p</sub>	P3	Position					
I <sub>xR</sub> Compensation	I <sub>xR</sub>	P2	Position					
<b>DIP Switches</b>								
ON	No.							
OFF	No.							

# Commissioning

<b>Setting-Current controller</b>			
Switch setting			
Switch S2	open	(off)	
	closed	(on)	
Switch S3 / Contact 1	60Hz	ON	
	50Hz	OFF	
<b>Measuring value</b>			
Armature voltage	max.	[V=]	
Armature current	peak	[A=]	
Armature current	steady	[A=]	
Tachometer voltage	max.	[V=]	
Acceleration	X4:16	[V/ms]	
Integrator	X4:14	[V/ms]	
<b>Motor data</b>			
Identification / name plate specifications			
Producer:			
Type		Serien-Nr.	
Motor voltage [V=]		Motor current [A=]	
Field voltage [V=]		Field current [A=]	
Tacho voltage [V/min <sup>-1</sup> ]		Tachometer type	
Brake [V]		Fan [V]	
Nominal speed [U/min]			

# Faults

## 7 Faults

### 7.1 Error diagnosis

Error diagnosis	
Malfunction	Causes
Motor does not run	<ul style="list-style-type: none"> <li>-Wrong power supply and motor connections</li> <li>-Activated fuses</li> <li>-Missing enable or command value</li> <li>-Current limit too low</li> <li>-Missing BTB</li> </ul>
Motor speeds up	<ul style="list-style-type: none"> <li>-Wrong polarity of the actual value (Tacho armature voltage)</li> <li>-Values of the tacho switch S9 too low</li> <li>-Command value too high</li> </ul> <p>For armature voltage control</p> <ul style="list-style-type: none"> <li>-Field current too low</li> <li>-Fuses, armature voltage feedback activated</li> </ul>
Motor runs unsteadily	<ul style="list-style-type: none"> <li>-Mechanical defect of the tacho</li> <li>-Tacho malfunction</li> <li>-Amplification on the speed controller too low or too high</li> <li>-Wrong PID parameter</li> <li>-Command value errors</li> <li>-Amplification of the current controller too low or too high</li> </ul>
No motor torque	<ul style="list-style-type: none"> <li>-Current limits too low</li> <li>-Field current too low</li> <li>-Mechanical overload of the axis</li> </ul>



## 8 Warranty

**We** guarantee that the device is free from material and production defects. Test results are recorded and archived with the serial number.

The guarantee time begins from the time the device is shipped, and lasts one year. WE undertakes no guarantee for devices which have been modified for special applications.

During the warranty period, we will, at its option, either repair or replace products that prove to be defective, this includes guaranteed functional attributes. We specifically disclaim the implied warranties or merchantability and fitness for a particular purpose. For warranty service or repair, this product must be returned to a service facility designated by us.

For products returned to us for warranty service, the Buyer shall prepay shipping charges to us and we shall pay shipping charges to return the product to the Buyer.

However, the Buyer shall pay all shipping charges, duties, and taxes for products returned to us from another country.

The foregoing warranty shall not apply to defects resulting from:

- \* improper or inadequate repairs effected by the Buyer or a third party,
- \* non-observance of the manual which is included in all consignments,
- \* non-observance of the electrical standards and regulations
- \* improper maintenance
- \* acts of nature

All further claims on transformation, diminution, and replacement of any kind of damage, especially damage, which does not affect our device, cannot be considered. Follow-on damage within the machine or system, which may arise due to malfunction or defect in the device cannot be claimed.

This limitation does not affect the product liability laws as applied in the place of manufacture (i. e. Germany).

**We** reserve the right to change any information included in this MANUAL.

All connection circuitry described is meant for general information purposes and is not mandatory.

The local legal regulations, and those of the Standards Authorities have to be adhered to. We do not assume any liability, expressly or inherently, for the information contained in this MANUAL, for the functioning of the device or its suitability for any specific application.

### **All rights are reserved.**

Copying, modifying and translations lie outside our liability and thus are not prohibited. Our products are not authorised for use as critical components in the life support devices or systems without express written approval.

The onus is on the reader to verify that the information here is current.