

CONTENTS

Page

Safety advice, standards and guidelines	3
General Information	4
Applications	5
Build	6
Characteristics	6
Technical data	7
Dimensions compact device	8
Dimensions transformers and chokes	8
Dimensions multiple-axes combination	9
Connections - flat version	10
Connections	11
Connection diagram	12
EMC advice	13
Connections - isolating transformer, compact device X3	14
Connections - mains module X10, motor power	15
Command value	17
Current limiting	18
Signals-drive ready BTB, analog parameter measurement	19
Terminal connections	20
Components	21
Circuit diagram	22
Adjustments	23-25
Adjustment advice	24-26
Speed actual value	25
Command value integrator	27
Current limiting	28
Speed control loop circuit	29
Adjustment without measurement equipment	29
Standard set-up	30
Commissioning	31
Faults	32-33
Signals	34
Protocol	35
Guarantee	36
I	

1 Basic-Information

Electronic equipment is not fault proof. This fact should be borne in mind for all possible operating conditions.

ATTENTION - High voltage
AC 140V~, DC 220V=

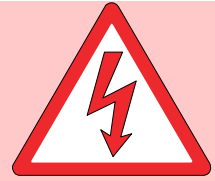

Before installation or commissioning begins, this manual must be thoroughly read and understood by the technical staff involved.

If any uncertainty arises, the manufacturer or dealer should be contacted.

TV3.2 devices are power electric parts used for regulating energy flow for power plants. Protection rating IP00.

Standards and Guidelines

The device and its associated components can only be installed and switched on where the local regulations and technical standards have been strictly adhered to:

EU Guidelines 89/392/EWG, 84/528/EWG, 86/663/EWG,
72/23/EWG

EN60204, EN50178, EN60439-1,

EN60146, EN61800-3

IEC/UL

IEC364, IEC 664, UL508C, UL840

VDE Regulations

VDE100, VDE110, VDE160

TÜV Regulations

Trade body guidelines VGB4

The user must ensure that in the event of :

- device failure
 - incorrect operation
 - loss of regulation or control
- the axis will be safely de-activated.

It must also be ensured that the machine or equipment are fitted with device independent monitoring and safety features.

Setting Adjustments

- should only be carried out by suitably trained personnel
- should only be carried out in accordance with health and safety guidelines
Installation
- should only be carried out when all voltages have been removed.

QS

Test results are archived with the device serial number by the manufacturer.

CE

The device adheres to the following: Guideline EU 89/336/EWG. EMV standards EN61000-2 and EN61000-4.

General Information

The transistor servo amplifier **SERVO-TV3.2** in combination with the dc motor provide a drive solution with a high control precision.

For dc motors the current is proportional to the torque and the voltage is proportional to the speed.

Current and voltage are precisely measured. The analog circuits are simply constructed.

The speed actual value is generated by the dc tacho generator.

The difference of the command value and the actual value is amplified in the speed control loop circuit (P-I-controller) of the servo drive. This results in the current command value.

For dc servo amplifiers which are supplied by a dc bus, it must be checked that the energy is fed back into the bus during brake operation (winding machines, lifts, great centrifugal masses).

The ballast circuitry is rated for 3% duty cycle. An extended operating time can be achieved by additional external resistors. (Option)

Information:

Further servo-amplifiers for dc servo motors

For low power applications	TV3, TV6	24-120V, 5-12A
	TV3.2 TG, IN, RS	24-140V, 5-10A
For high power applications	Q2, Q6	up to 250V, 15-60A
	TVQ6.2	up to 250,10-25A

Amplifiers for dc shunt-wound motors

For low power applications	C1, C2	up to 180V, 4-12A
From medium to highest power applications	Q1, Q2, Q3, Q6	up to 550V, 15-2000A

Three-phase servo amplifiers for ac synchro servo motors

For low power applications	TVD3.2 -bl, IN, RS	24-100V, 5-10A
For medium power applications	TVD6-200 bl, N, RS	200V, 5-25A
	TVD6.2-400 bl,IN,RS	400V, 5-25A
For high voltage applications	AS 250/275, AS 450/475 bl, IN, RS	

Digital servo-amplifier

DS200, DS400 IN, RS

Servo-amplifier for battery operation

BAMO C24
BAMO A1, A2, A3
BAMO D3

TG = tacho generator
bl = brushless tacho
IN = incremental encoder
RS = resolver

Applications

Machines and installations for all types with a drive power of up to 0.8kW.

Especially as 4Q-servo-drive for feed axes where the following is required:

- high dynamic acceleration and braking cycles
- a wide control range
- high efficiency
- small motor dimensions
- highly repeatable, accurate and quiet moves

For speed or torque control or combined speed/torque control incorporated within or independent of position control loops.

Drives with constant speed as in conveyors, spindle drives, pumps, transversal or longitudinal pitch drives.

Particularly suitable for:

component equipment inserting machines, sheet-metal working machines, machine tools, plastic working machines, assembly machines, knitting and sewing machines, textile working machines, grinding machines, wood and stone working machines, metal working machines, food processing machines, robots and handling systems, conveyors, extruders, calenders, and many other machines and installations.

DC drives run very accurately and quietly and they have a uniform torque.

Note

Use of these drives where braking operations are predominant, e.g. when deceleration is mainly required:

- winding machines, lifts, great centrifugal masses



The braking energy is annihilated in the ballast circuitry or fed into the mains through the use of an external dc bus converter.

Energy compensation is possible for drives with several axes.

Build

- Switch cabinet mounting or 3HE plug-in device according to the VDE, DIN and EU regulations
- Standard analog control electronics
- Power electronics for 5A and 10A
- No galvanic isolation between the power connection and device ground (GND)
GND = -UB = PE - housing

Components

- IGBT power semiconductors, comfortably over-dimensioned
- Only components customary in trade and industrially standardised are used
- SMD basic equipment
- LED displays
- 4 position binary switches for system set-up
- Precision potentiometers for fine adjustment

Characteristics

- * Connection using an isolating transformer max. 140V~
- * Differential command value input
- * Speed and torque control
- * Static and dynamic current limiting
- * Current command value output
- * Measurement points for current and speed
- * Enable logic
- * Emergency stop
- * Braking in case of a mains failure
- * Temperature watchdog for the motor and the device
- * Incremental encoder output

Compact device dimensions

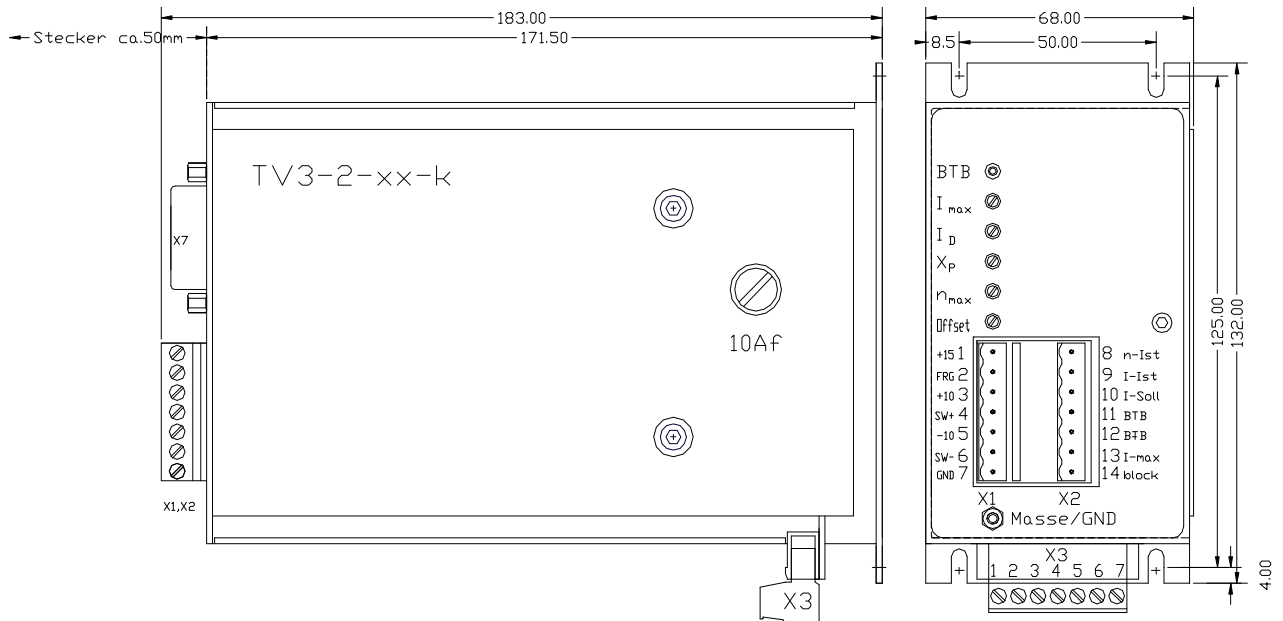

Transformer and choke dimensions

Transformer - type	Transformer power VA	Dimensions a / b / c mm	Weight kg
TE 8/2	100	85x 89x 82	2.0
TE 12/1	250	120x101x115	4.3
TE12/3	400	120x133x115	6.8
TE 15/1	500	108x132x122	8.2
TE 15/3	800	150x150x132	13.5
TE 74/2	1300	175x140x160	15.4
TE 74/3	1600	175x150x160	18.5

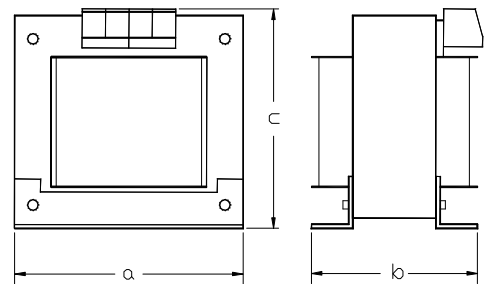

Choke type	Rated current A	Induc. mH	Dimensions a / b / c mm	Weight kg
2M5-4	4	2.5	60x 85x 65	0.7
2M6-8	8	2.5	70x 90x 75	1.2
2M7-12	12	1.5	80x 105x 86	1.4

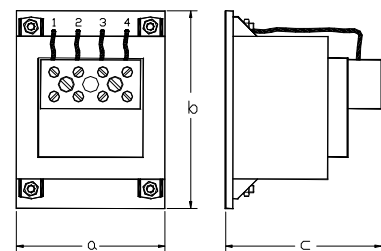

Connectiona - flat Version

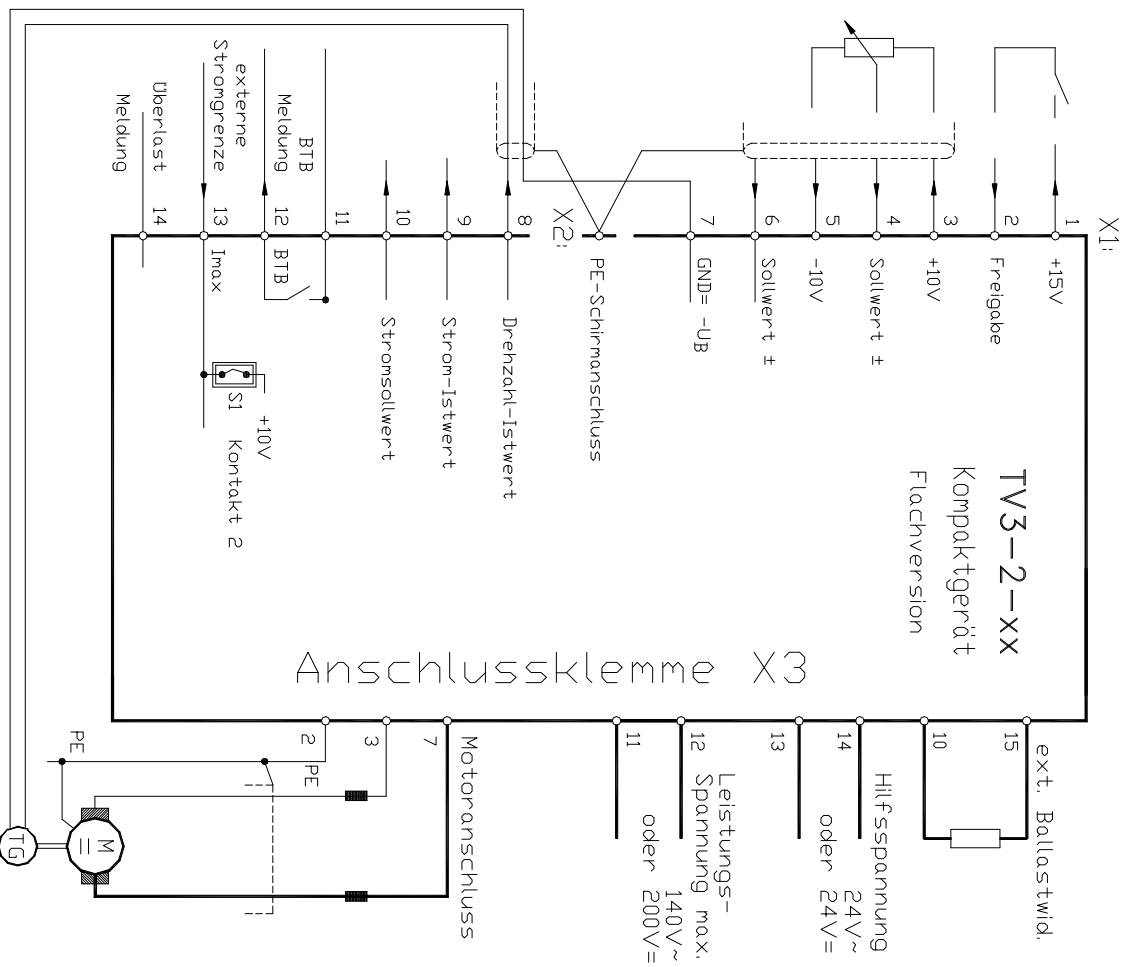
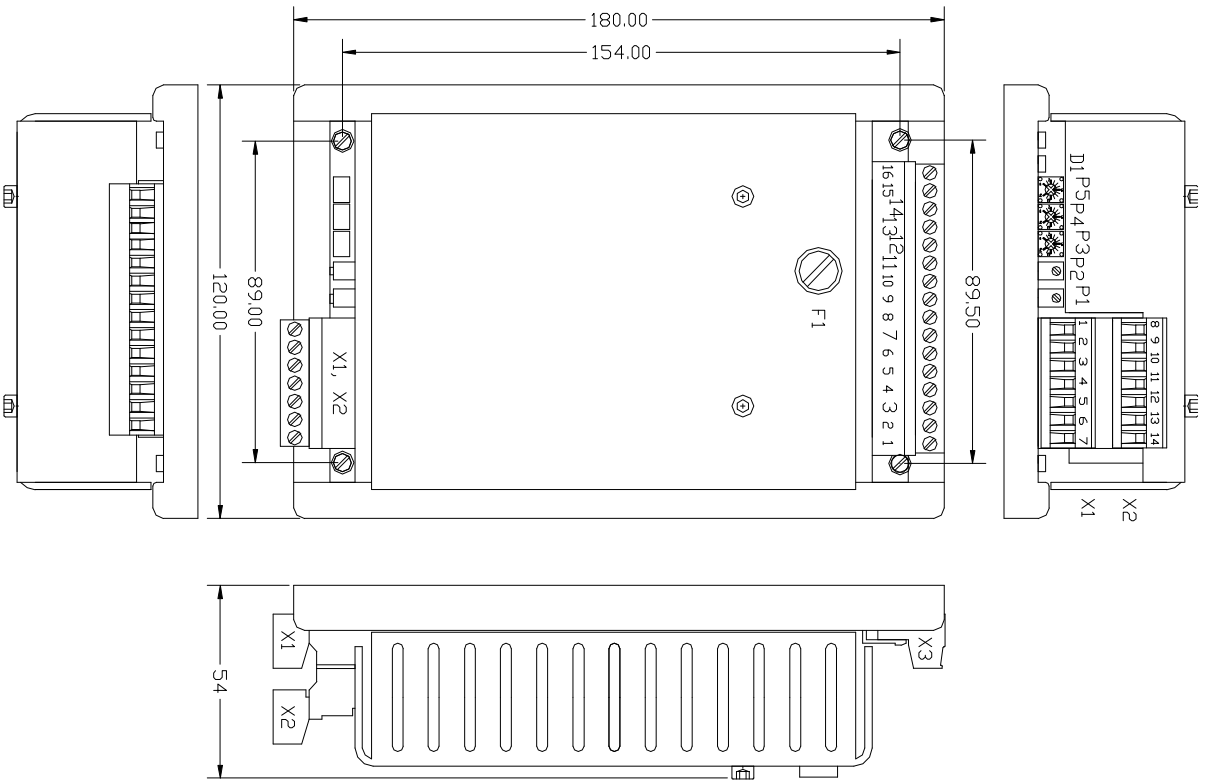

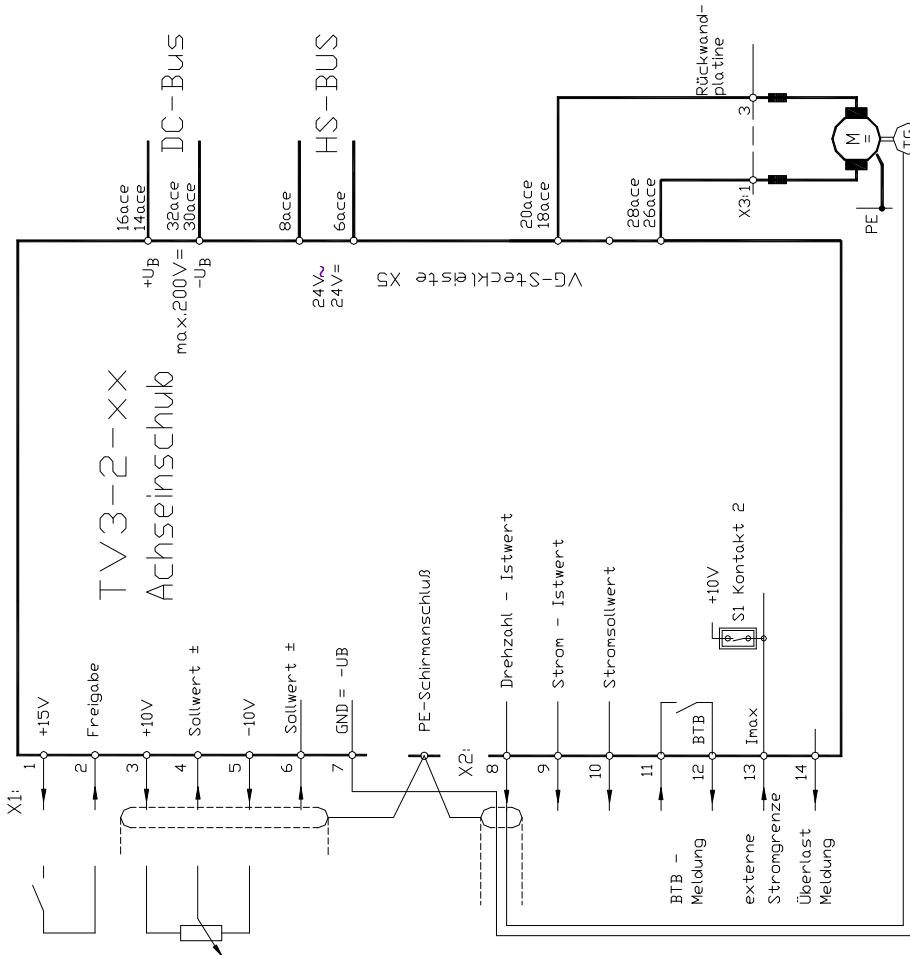
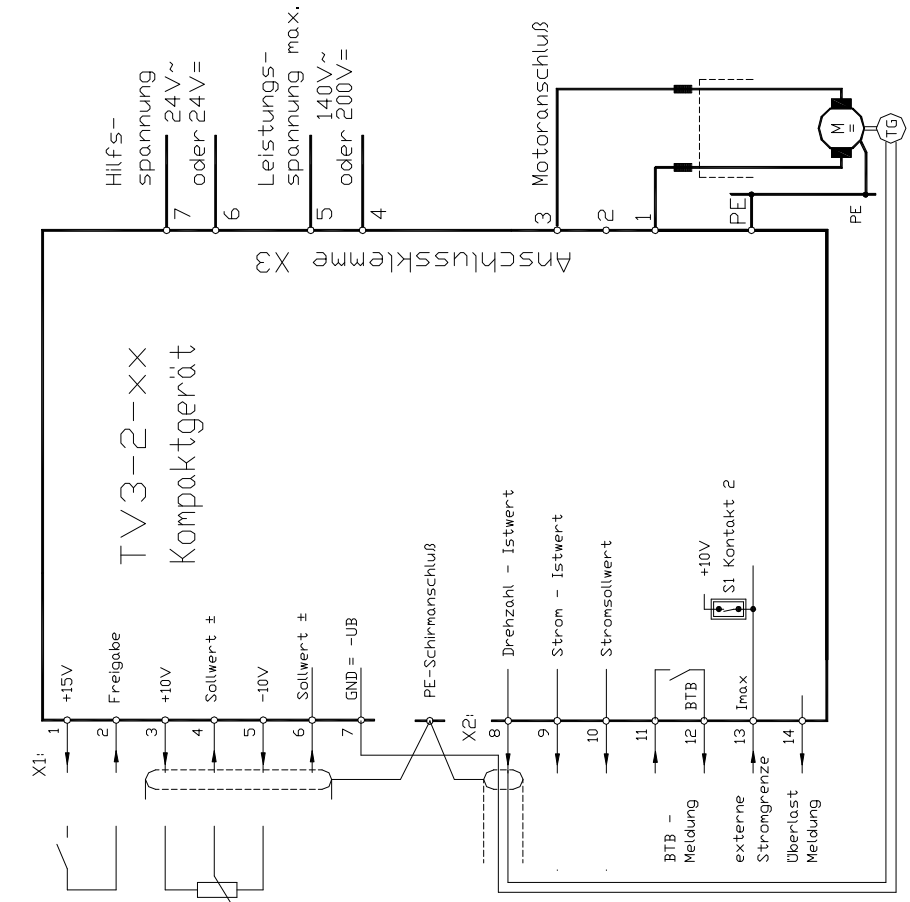

compact device

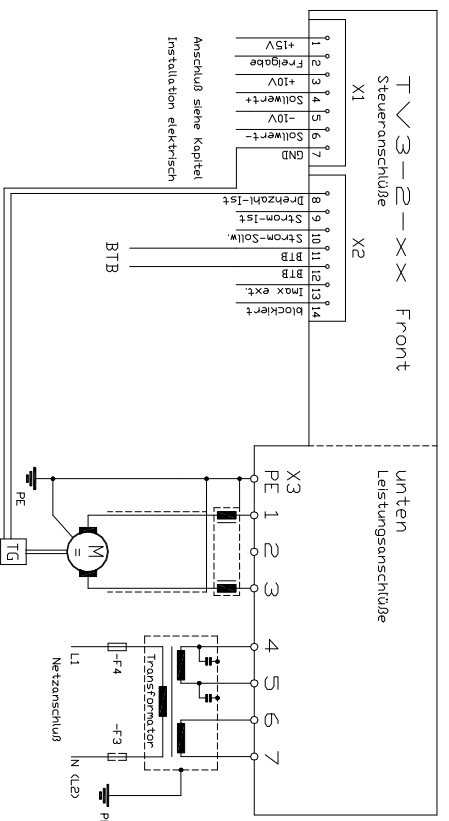

multiple axes combination

Mehrachs- Rackaufbau

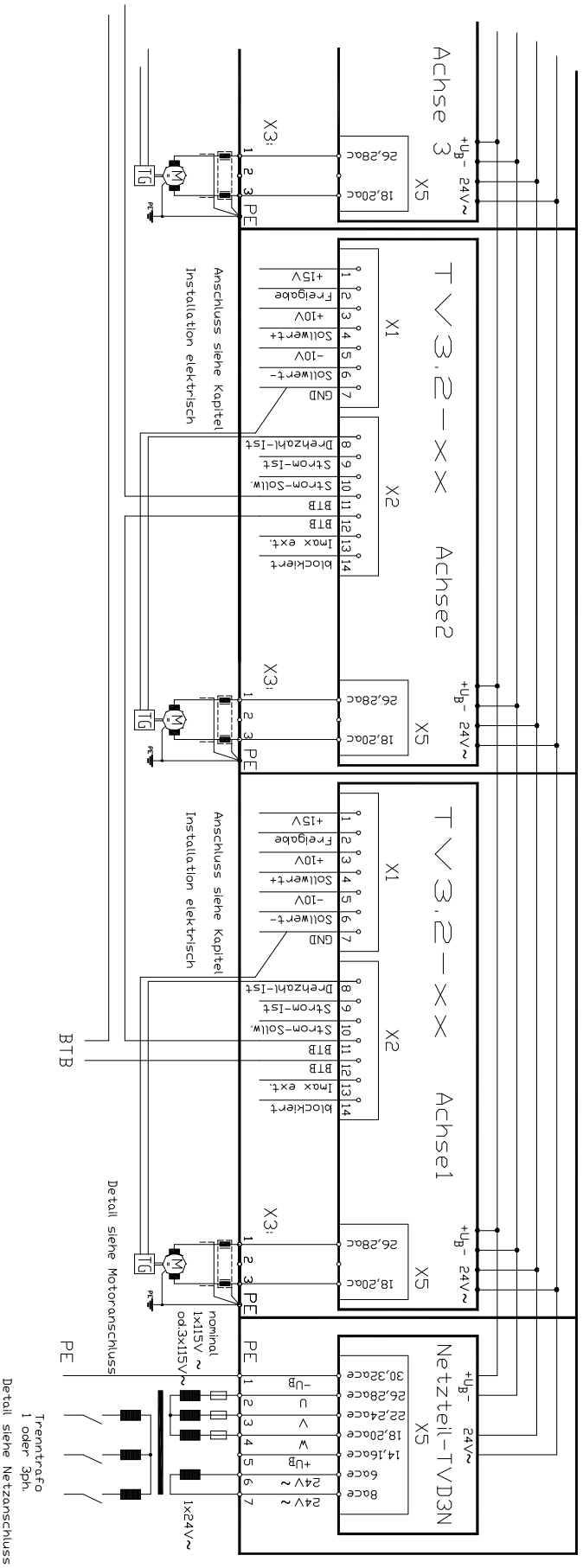

Connection Diagram

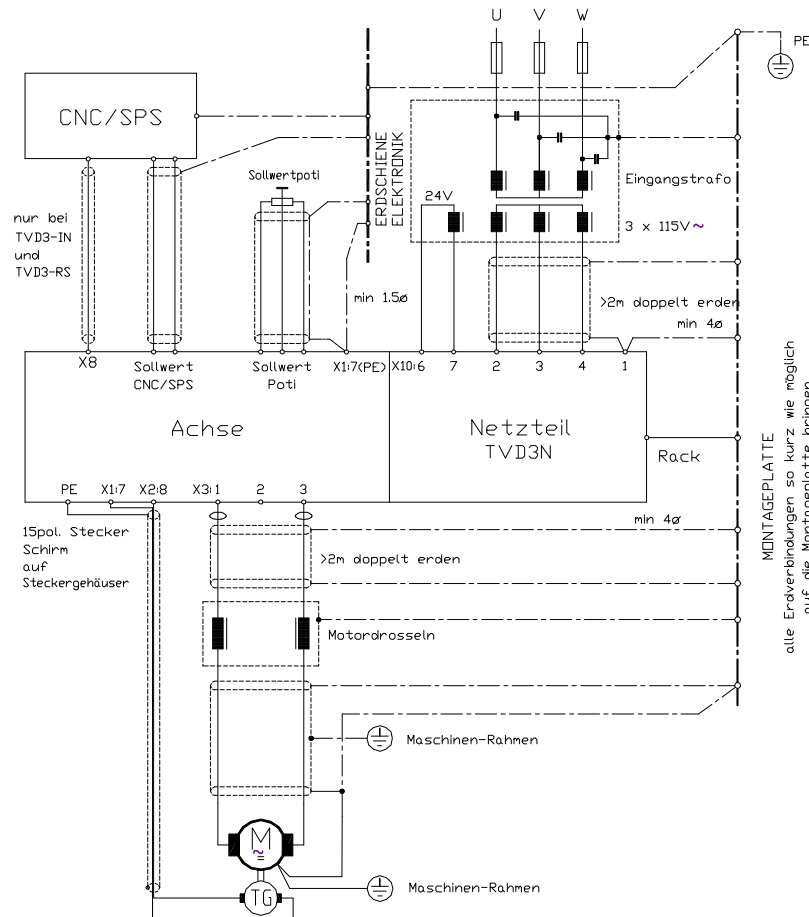

EMC Advice

The devices adhere to the EU guidelines 89/336/EWG and the technical standards EN 61000-2 and 61000-4 provided that the following conditions are observed:

- The device, the transformer, motor chokes and power line filter are conductively mounted on a 500x500x2 mm mounting plate.
- The mounting plate must be connected to ground using a 10mm² wire.
- The motor housing must be connected to ground using a 10mm² wire.
- The device ground X1:7 must be connected to the mounting plate using a 2.5mm² wire.
- X10:1 (-U) must be connected to the mounting plate using a 4mm² wire, l=50mm.
- The rack ground screw must be connected to the mounting plate using a 4mm² wire, l=50mm.

Single-phase connection:

Transformer with filter type :

TE8/2 F to TE17/3 F

Conductor length between the device and the power line filter <100mm

Three-phase connection:

Transformer with filter type :

DT3/50 F to DT4/75 F

Motor connection:

Motor conductor choke type:

5A= MD66-5 10A= MD78-10

Motor conductor l = 1.5m, 4-core, shielded.

Shield must be connected to the mounting plate on the device side as well as to the ground on the motor side.

Connection of the control conductors:

All control conductors must be shielded, 1.5m. Shield must be connected to the ground.

Warning:

The order of the connections to the connector numbers or screw terminals is obligatory. All further advice is non-obligatory.

The input and output conductors may be altered or supplemented in accordance with the electrical standards.

Note:

- connection and operating instructions
- local regulations
- EU guideline 89/392/EWG
- VDE and TÜV regulations and Trade body guidelines
- CE and EMC advice



Connection with an isolating transformer

Note:

- The relay contacts must be rated according to the transformer switch-on current.
- Slow fuses must be installed at the input of the transformer
- The fuses must be rated according to the transformer current
- Quick fuses must be used at the output of the transformer
- The fuse value for each mains module is max. 30AF

Isolating transformer

Rated transformer power [VA]= $1.42 \times 115 \times I_M \times GLF \times nF$

I_M = Sum of the motor currents (effective)

GLF = simultaneity factor

nF = speed ratio factor

GLF =

1 with 1 motor

0.5 ... 0.7 with 2 motors

0.4 ... 0.6 with > 2 motors

nF =

effective speed

maximum speed

Connection compact device X3

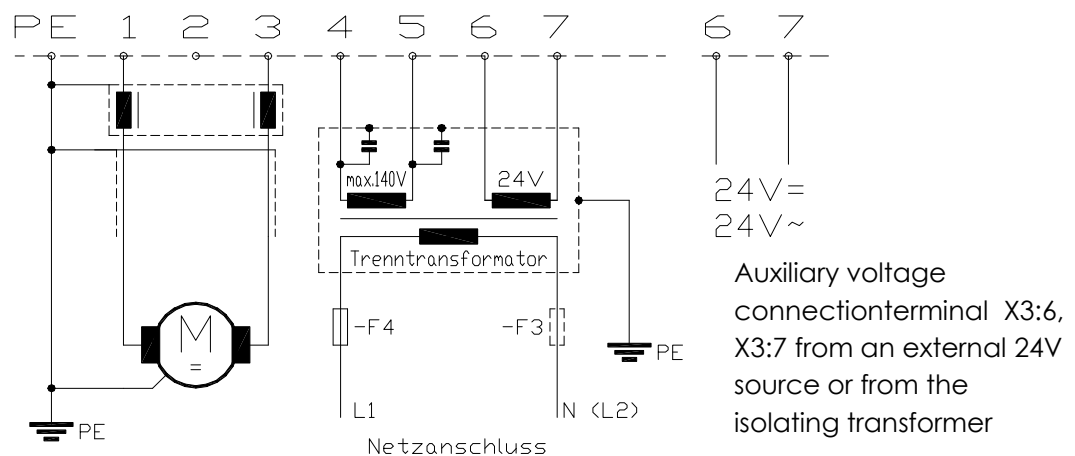

3 Electrical Installation

Connection to the mains module X10

Alternating voltage
1x 115V + 24V

Three-phase voltage
3x115V + 24V

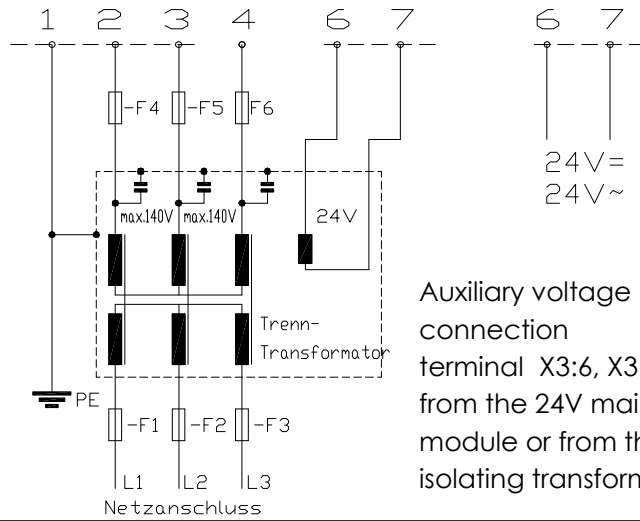
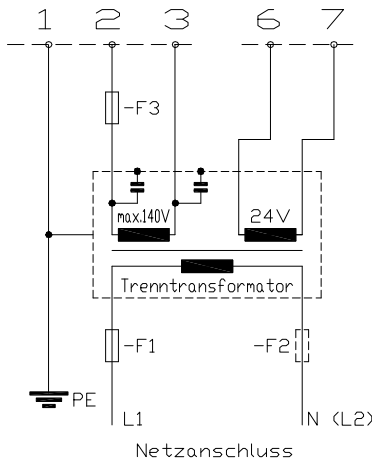

Auxiliary voltage connection
terminal X3:6, X3:7
from the 24V mains module or from the isolating transformer 20~

Connecting cable			
Dimensioning	5A	10A	Mains module max. 30A
Conductor cross-section mm ²	0.5	0.75	2.5
Fuses	- safety fuse AF	10	16
	- automatic cut-out A	10	16

Motor power connection

Cable no.	PE	M1	M2
Connection	PE bolt	X3:1	X3:3
Motor cable for	5A	10A	thermal brake
Cross-section	0.75	1.5	0.5 0.5

Cable type 2x motor conductor + PE **shielded**
+ (if required: 2x thermo+2x brake)

Shielding

- with earth clamp
- directly to be connected to the switch cabinet input and to the motor
- multiple earthing in case of long conductor cables

Magnetic cores

- against HF failures

Motor chokes

- against LF failures
- against high leakage currents
- for motor efficiency
- for motor life

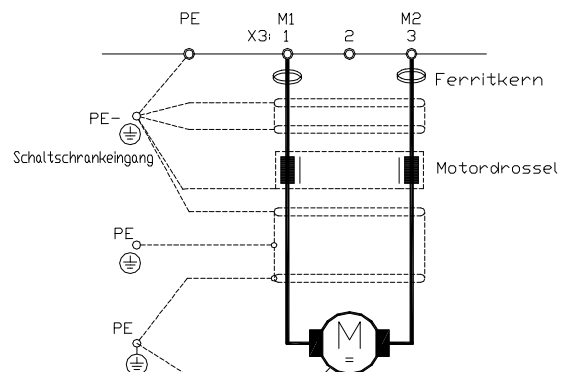

The connection advice is a general information and it is non-obligatory.

Adhere to:

- connection and operating instructions
- local regulations
- EU guideline 89/392/EWG
- VDE and TÜV regulations and Trade body guidelines



Connection no. terminal connector
X1:1 to X1:7 and X2:8 to X2:14

Signal conductors

Shielded and separated from power conductors,
command value pairs twisted and shielded.

Logic connections

Relays with gold contacts or reed relays. Contact current 6mA

Drive enable - internal logic voltage

- internal logic voltage X1:1 +15V/10mA
- contact circuit between X1:1 and X1:2

Drive enable - external logic voltage

- drive enable voltage +10 to +30V X1:2
- GND X1:7

Drive enabled

- command value and speed control loop circuit are immediately active

Drive disabled

- emergency stop
- command value >>> switched internally immediately to 0
- after 2 seconds >>> speed control loop circuit is de-activated

Braking in case of a mains failure

Braking function

- command value switched to 0V in case of a mains failure
- max. braking time 150ms

Feed-back to the bus circuit

Speed command value

Voltage source for command values $\pm 10V$, 10mA

+10V	X1:3
-10V	X1:5
GND	X1:7

Command value inputs

- command value voltage max. $\pm 10V$ =
- differential input
- input resistance 50 k Ω
- relay contacts: use gold or reed contacts



Attention:

Command value pairs should be twisted and shielded. The shield should be connected on one side only.

Connections

Command value with an internal voltage source

Command value	X1:4 (signal)
	X1:7 (GND)

Bridge	X1:6 — X1:7
--------	-------------

Command value from an external PLC/CNC voltage

Command value	X1:4 (signal)
	X1:6 (GND)

Command value current from an external PLC/CNC

Resistor for a current command value of 0 to $\pm 20mA$ $R_{com.} = 500 \Omega$

Current command value	X1:4 (signal)	X1:6 (GND)
-----------------------	---------------	------------

Internal supply

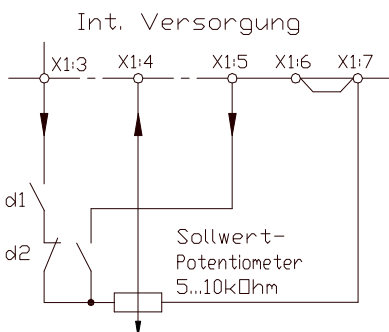

CNC/PLC

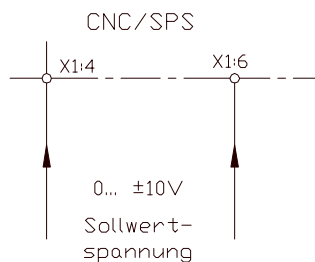

Current com. value

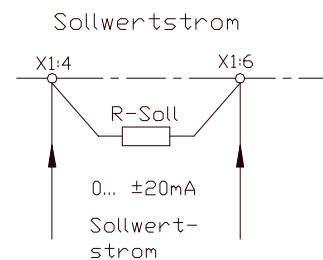

Attention:

Do not use a command value current of 4 to 20mA !



External current limiting

Voltage source for an external current limit

+10V/10mA	X1:13
GND	X1:7

Range:

0 to + 5V	>>>	0 to 100% rated device current
0 to +10V	>>>	0 to 200% rated device current
internal over-current watchdog	>>>	max. 5sec.

Current limit input

Max. input voltage +10V

Input resistance 10 kΩ

Internal attenuation with potentiometer I.

Relay contacts: use gold or reed contacts

Switch S1, contact 2 = OFF

Connections

Current limit	X2:13	(signal)
	X1:7	(GND)

Internal source

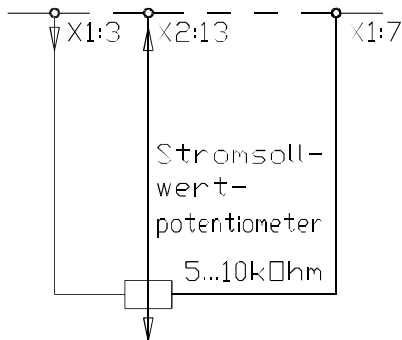

CNC/PLC

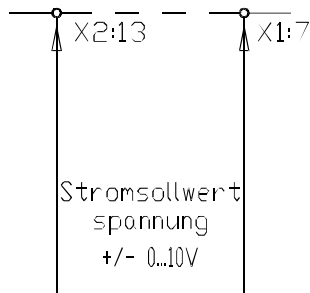

Current command value

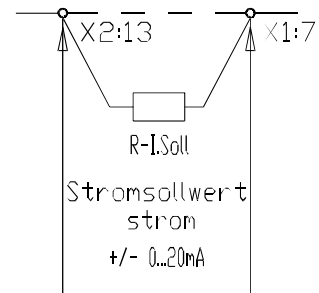

Attention:

When internally adjusting the current limit
Switch S1 >> contact 2 = ON



Drive ready - BTB signal

Relay RL1

Signal contact X2:12 - X2:13
 Switch rating max. 48V, 0.5A

The BTB contact signals to the PLC/CNC that the drive is functional.
 The BTB signals of several axes can be connected in series.

Delay time after switching on the power supply >> max. 1sec.

Display

Drive ready	LED bright green	contact closed
Fault	LED bright red	contact open

BTB contact drops in case of

over-temperature controller, motor	not saved
over-voltage	saved
short-circuit, short-circuit to earth	saved
voltage error	not saved
bus circuit error	not saved

To clear the error re-enable the drive (switch off/on)



Attention:

In any case the BTB contact (drive ready) must always be used with the CNC/PLC or wired into the emergency stop circuit.
 It is possible that the drive initiates motion without being instructed to do so.

Fault memory

Fault saving is not effective for all errors!

Signal blocked

Current demand	normal	overload
Output X2:14	>+10V/6mA	<+2V

Analog parameter measurement outputs

Function	Motor current	Speed
Connector	X2:9 - X1:7	X2:8 - X1:7
Measured value	2.5 V = Typecurrent 5.0 V = peak current unipolar positiv	Tachovoltage at the input of the divider bipolar
Ausgangswiderstand	1 kOhm	4.7 kOhm

Control connections

Function

+ 15 Volt (for enable)
 Enable input(+10 to +30 Volt)
 + 10 Volt (for command value)
 Command value + input
 - 10 Volt (for command value)
 Command value - input
 GND
 Speed actual value output
 Current actual value output
 Current command value output
 BTB contact
 BTB contact
 External current limit input
 blocked output
 Power connections - compact device

Terminal no.

X1: 1
 X1: 2
 X1: 3
 X1: 4
 X1: 5
 X1: 6
 X1: 7
 X2: 8
 X2: 9
 X2: 10
 X2: 11
 X2: 12
 X2: 13
 X1: 14

Function

Motor 1
 not assigned
 Motor 2
 Power
 Voltage
 Auxiliary voltage

Terminal no.

X3: 1
 X3: 2
 X3: 3
 X3: 4
 X3: 5
 X3: 6, X3: 7

Power connections - plug-in unit

Function

Bus circuit - (UB-)
 Motor 1
 not assigned
 Motor 2
 Bus circuit + (UB+)
 24V~
 24V~

Plug-in connector

X5: 30, 32 ace
 X5: 26, 28 acc
 X5: 18, 20 ace
 X5: 14, 16 ace
 X5: 8 ace
 X5: 6 ace

Terminal no.

X3:PE
 X3: 1
 X3: 2
 X3: 3

Mains module - plug-in unit

Function

Bus circuit - PE (UB-)X5:
 Power U
 Power V
 Power W
 Bus circuit + (UB+)
 Auxiliary voltage

Plug-in connector

30, 32 ace
 X5: 26, 28 acc
 X5: 22, 24 ace
 X5: 18, 20 ace
 X5: 14, 16 ace
 X5: 8 ace
 X5: 6 ace

Terminal no.

X10: 1
 X10: 2
 X10: 3
 X10: 4
 X10: 5
 X10: 6
 X10: 7

Components

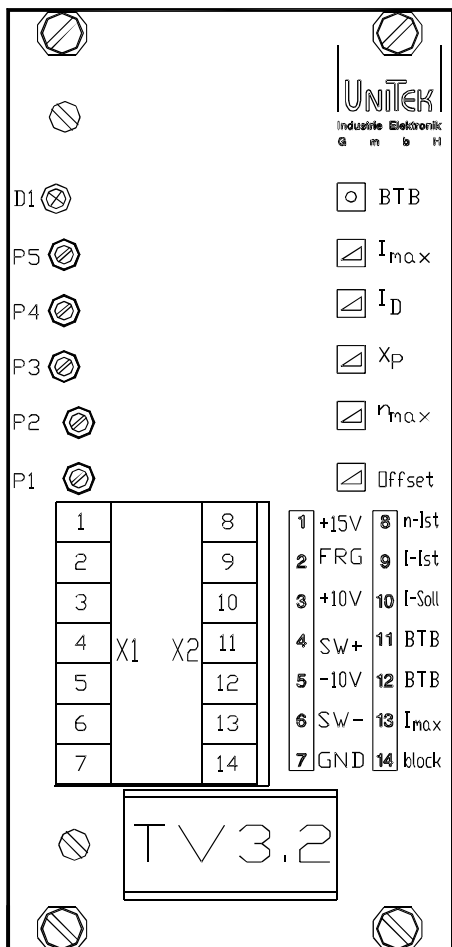
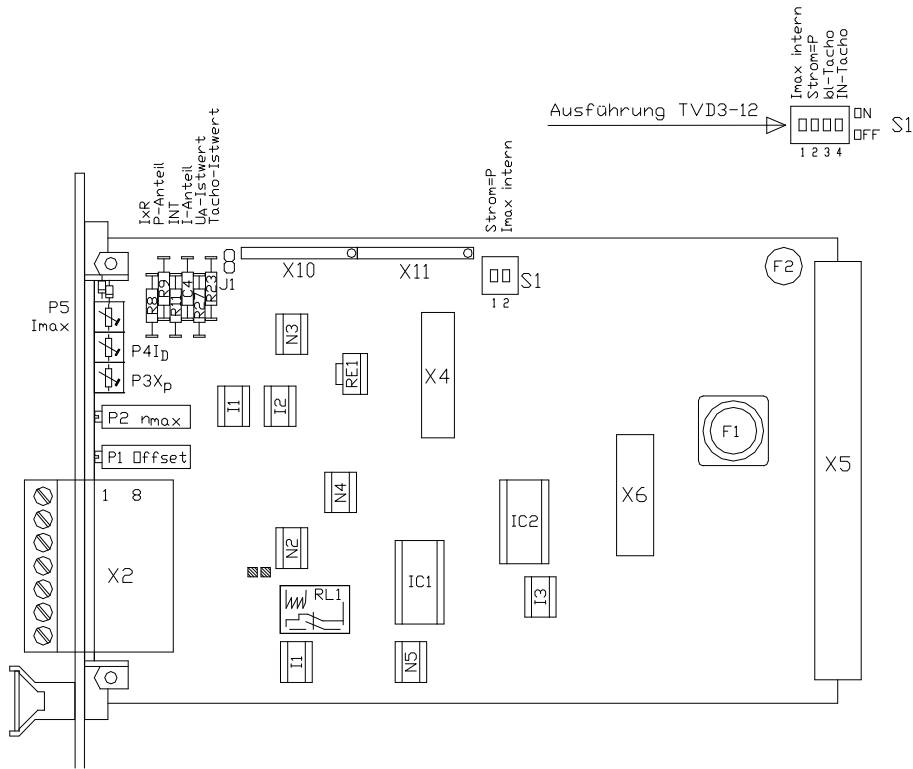

Anzeige

D1 green BTB
D2 red Fault

Poti

P5 I_{max}
P4 I_D
P3 X_P
P2 n_{max}
P1 Offset

Stecker

X1:1 +15V
X1:2 enable
X1:3 +10V
X1:4 com.value +(-)
X1:5 -10V
X1:6 com.value -(+)
X1:7 GND

X2:8 n-act.value
X2:9 I-act-value
X2:10 I-com.value
X2:11-12 BTB- contact
X2:13 ext.current limit
X2:14 blocked

Servo - Drive TV3.2 -xx

Circuit Diagram

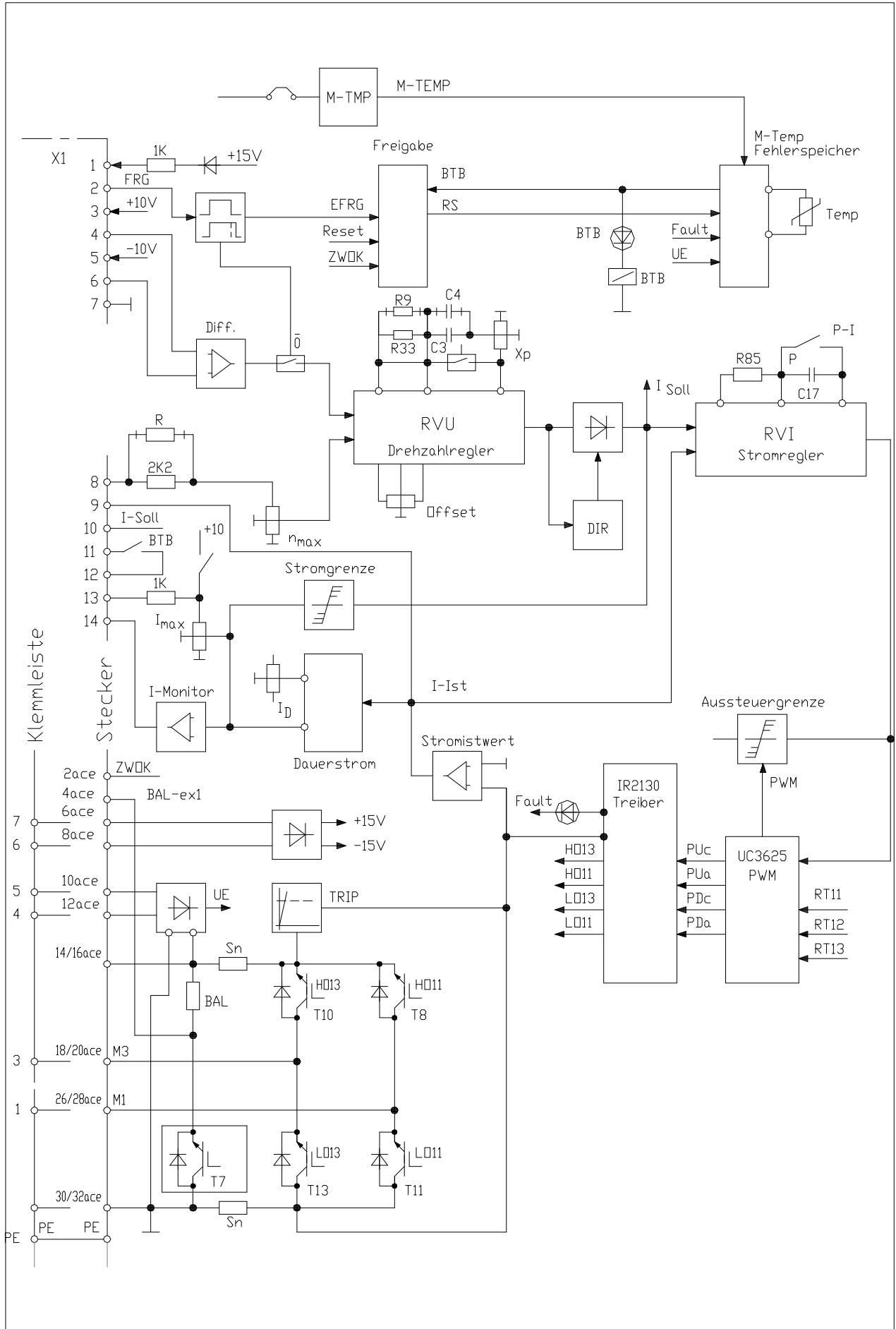

Adjustments			
Function		Component	
Actual value adjustment bl tacho		Poti P2 (n_{max})	
Actual value adjustment option dc tacho		Resistor R + poti P2 (n_{max})	
Internal current limit		Switch S1 > contact 2=ON Poti P5 (I_{max})	
External current limit		Switch S1 > contact 2=OFF Poti P5 (I_{max})	
Continuous current		Poti P4 (I_D)	
Amplification P-component		Resistor R9 Poti P3 (X_P)	
Amplification I-component		Capacitor C4	
Zero adjustment		Poti P1 (offset)	
Switch S1			
Function	contact	ON	OFF
current limit	2	internal	external
current amplification	1	P	PI
LED display			
BTB	green	LED 1	
fault	red	LED 2	
Signal outputs			
Function	Designation	Terminal no.	
Speed	n-actual value	X2:8	
Current	I-actual value	X2:9	
Current command value	I-command value	X2:10	
blocked	>10V/6mA	X2:14	
BTB -contact	BTB/fault	X2:11, X2:12	

Adjustment advice

Adjustments

- to be carried out only by qualified personnel
- observe all safety regulations
- follow the correct adjustment sequence

Pre-settings

- | | |
|---------------------------------|--------------------------------|
| Actual value | >>> rough tacho adjustment R23 |
| Current limit internal/external | >>> switch S1, contact 2 |
| Current control P- PI | >>> switch S1, contact 1 |

Optimisation

- | | |
|-------------------------|---|
| Actual value adjustment | n_{max} adjustment |
| Current control | witch S1, contact 1 (basic set-up > ON) |
| Current limits | I_{max} , I_D -adjustment |
| Speed control | X_P -adjustment, variable components |
| Zero point | offset adjustment |
| Path-/position control | in the CNC/PLC |

Attention:

Always optimise beginning with the innermost control loop and work out.
Sequence: current loop>speed loop>position loop (CNC/PLC)

Test points

Measurement	max.	Connector
Command value	±10V	X1:4
Speed act. value at the output of the divider	± 5V	X2:8
Current actual value unipolar	+ 5V	X2:9
Current com. value (control func. speed controller)	-10V	X2:10

Command value

Function	max.	Connector
input signal	±10V=	X1:4
input GND		X1:6

The signal and the GND connection can be swapped.

Command value as current signal

- | | |
|---|----------------|
| Command value from an external current source | 0 to ± 20mA |
| External load resistance for the command value | 0 to max. ±10V |
| Com.value resistance $R_{com}[\Omega] = \text{com.value voltage} / \text{com. value current}$
(max. 500 Ω) | |

Attention: Do not use a command value current of 4 to 20mA



5 Adjustment

Speed actual value

DC tacho generator Connector

Input X1:7	=	Tacho (GND)
Input X2:8	=	Tacho (signal)
PE bolt	=	Shield
Jumper J1	=	not plugged

Command value input X1:4 positive >>> tacho input X2:8 positive

Tacho voltage at max. speed

Limit values >>> min. 5V=, max. 160V=

Pre-settings

by means of the resistance R23

Tacho voltage range

- without R23 >>> 15V= to 160V=
- with R23 1kOhm >>> 5V = to 55V=

Armature voltage control

internal feed-back

Pre-settings

Resistance R23 >>> 0 Ω bridge
Jumper J1 >>> plugged

IxR compensation

Resistance R167 [k Ω]= Motor resistance x ...

Fine adjustment

by means of potentiometer n_{max} (P2)

Command value from the potentiometer:

- with a 1V command value: adjust the speed to 10% of the maximum required
- with a 10V command value: make fine adjustment to achieve 100% max.speed

Command value from a CNC/PLC:

- with a 0.8V command value: adjust the speed to 10% of the maximum required

Direction change

Swap the command value connections X1:4, X1:6
or swap the motor and the tacho connection



5 Adjustment

Command value integrator

Linear integrator

Time adjustment by means of resistor R11 (INT)

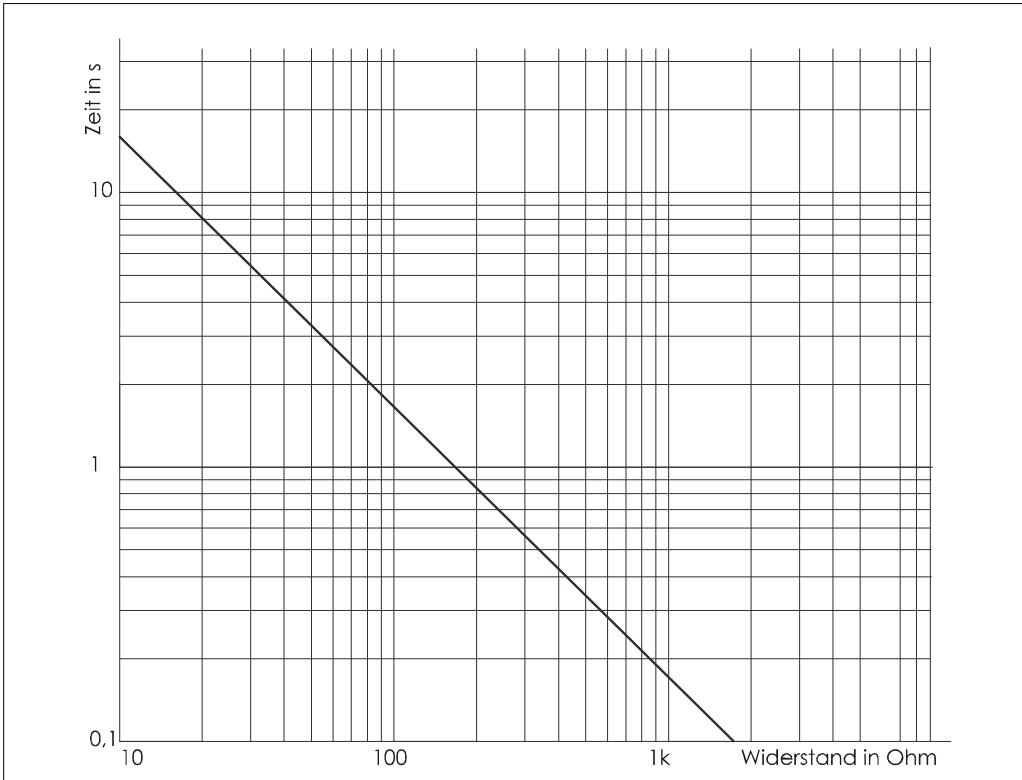

Current limiting

Peak current	range 0 to 200% rated current max. reset time 5sec.	Poti I _{max} (P5)
Continuous current	range 5 to 100% rated current	Poti I _D (P4)

Internally resetting current limits

Current limit	Function	Limit
overload	time	continuous current
Signal to X2:14	blocked	

The lowest current limit is effective!

Peak current

Internal current limit (standard set-up)

Adjustment	Input	Switch	Poti
I _{max}		S1, contact 2=ON	I _{max1} (P5)

External current limit

I _{max}	X2:13 0 ... +10V	S1, contact 2=OFF	I _{max1} (P5)
------------------	------------------	-------------------	------------------------

The external current limiting voltage can internally be reduced by means of the potentiometer I_{max}.

Continuous current

The motor protection for both torque directions is adjusted to motor rated current by means of the potentiometer I_D (P4).

Measuring adjusted values:

- Do not connect motor
 - Set the command value and enable >>> switch off/on
- Measured current command value X2:10 (5V = rated current)

Command value	Measured value I _{max} (approx. 2sec.)	Measured value I _D
+5V	0 to max.10V	0.25 to max. 5V
-5V	0 to max.10V	0.25 to max. 5V

Current actual values

Measured current actual value	X2:9	I _{max}	= 0 to +5V
		I _D	= 0.12 to +2.5V

Attention:

for an exact torque control:

- a PI-current control switching is necessary
- the device is adjusted to P-control in the factory
- change from P- to PI-control in the current control loop
- switch S1, contact 1 = OFF



5 Adjustment

Speed control loop circuit

- variable components R9, C4
- amplification potentiometer P3 (XP)
- Take over the adjusted values when the device is exchanged

Standard set-up

- fixed R, C values: 220 kΩ, 22nF
- amplification potentiometer XP to 50%
- suits the majority of drives

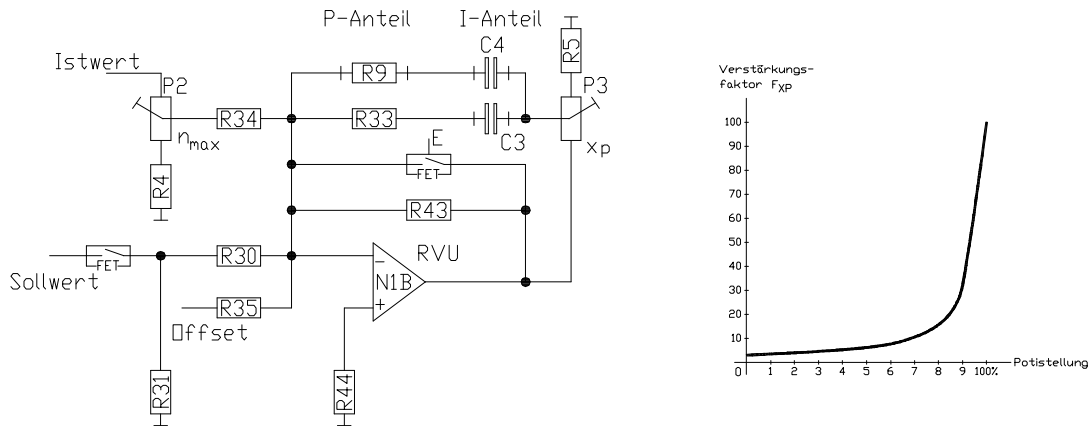

Adjustment without measurement equipment

- Connect the motor,
- command value = 0
 - XP = 50%
 - R, C = basic values

Enable the drive,

- Turn the potentiometer XP clockwise until the axis begins to oscillate
- Turn the potentiometer XP anti-clockwise until the oscillations disappear
- Turn the potentiometer XP another 2 clicks anti-clockwise

Drive behaviour:	
amplification too low	amplification too high
Long-wave oscillations 1 to 0.1Hz	short oscillations 30 to 200Hz
Large overshoots	vibrates during acceleration
OVERRUNS destination position	vibrates during braking and in position

Attention:

Drive connected to CNC/PLC controllers

For the maximum speed output from the controller, adjust the speed command value to between 8V and 9V by means of the potentiometer n_max.



Standard set-up

Before commissioning check the following connections

Nominal power supply 115V~/180V=, maximum 140V~/200V=

Compact device

- Power supply	compact	terminals X3:4, X3:5,
- Auxiliary voltage	compact	terminals X3:6, X3:7
- Motor connection	compact	terminals X3:1, X3:3

Multiple axes combination

- Power supply	mains module	terminals X10:2, X10:3, X10:4
- Motor connection	axis	terminals X3:1, X3:3
- Protection earth		earth screw on the housing
- Motor-earth connection		earth screw on the housing

Always observe the connection advice.

Power connections

- Protection earth	PE bolt
- Mains	1x or 3x 115V~
- Motor	2x motor conductors + protective conductor +shield
- Encoder connection	observe the motor-specific connection data sheets

Control connections

- Enable	contact between X1:1 and X1:2
- Command value	signal X1:4, GND X1:6 in case of an internal poti supply, bridge between X1:6-X1:7
- Actual value tachometer	signal X2:8 GND X1:7

Standard set-up for the first commissioning

Potentiometer	I_{max1}	peak current	20%
Potentiometer	ID	continuous current	100%
Potentiometer	XP	amplification	50%
Potentiometer	n_{max}	speed	left full scale
Switch	S1	contact 1	= ON
		contact 2	= ON

6 Commissioning

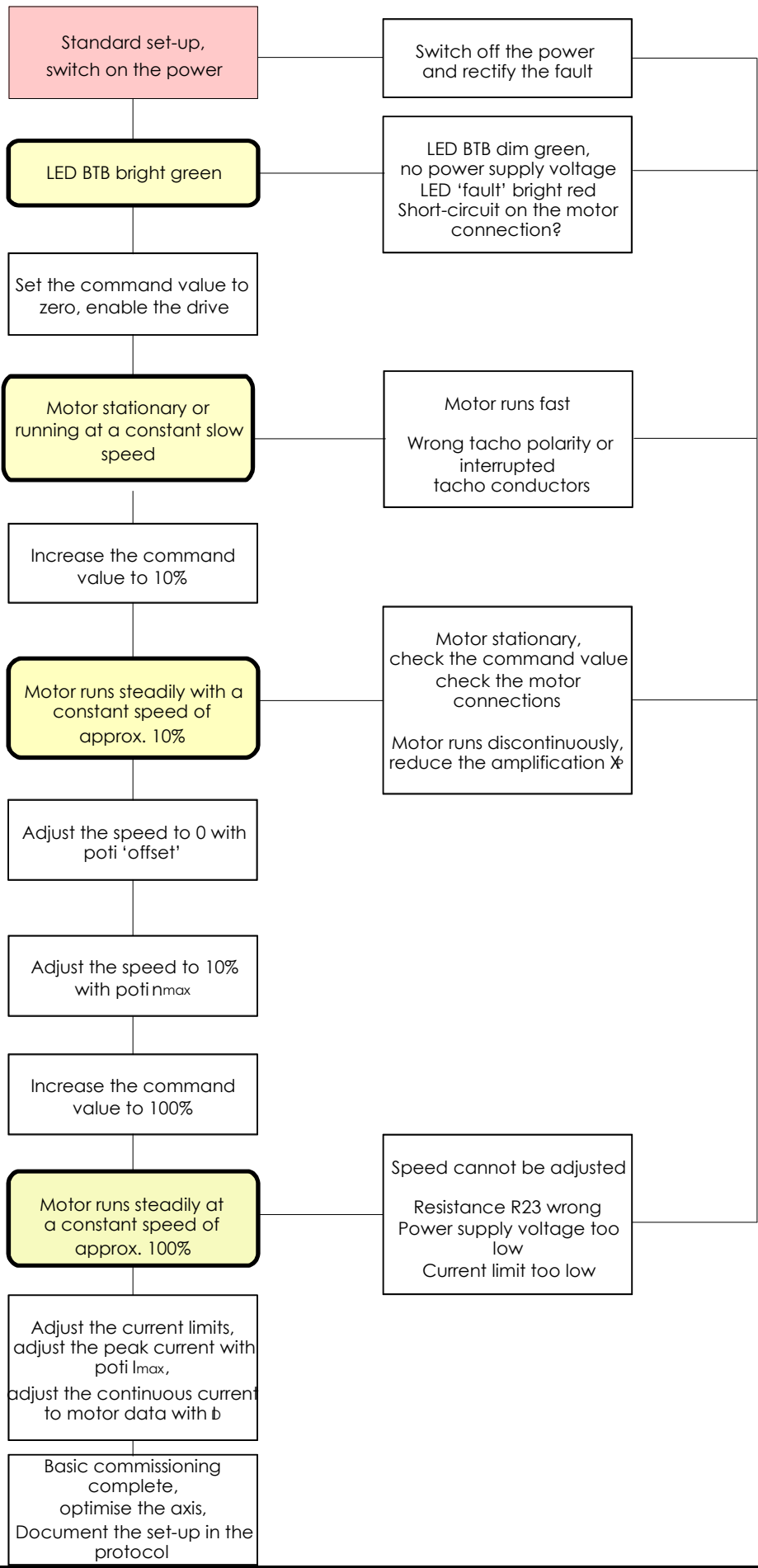

Faults

FehlerFault	CausesUrsachen
LED dim green	<ul style="list-style-type: none"> - No power supply connection, - Power supply voltage too low
LED 'fault' bright red	<ul style="list-style-type: none"> - Short-circuit on the motor connection - Final stage fault - Over-voltage
Motor stationary, no torque	<ul style="list-style-type: none"> - no enable - current limit I_{max} at left full scale - Motor connection interrupted
Motor speeds up	<ul style="list-style-type: none"> - Wrong tacho polarity - Tacho connection interrupted
Motor runs unsteadily Motor läuft unruhig	<p>Verstärkung X_p zu hoch. Sollwertstörungen- Amplification X_p too high</p> <ul style="list-style-type: none"> - Command value failures
Amplifier switches to failure, LED bright red	<ul style="list-style-type: none"> - Over-temperature, phase short-circuit or short-circuit to earth, BTB fault, - Output stage failure
Speed cannot be adjusted with poti n _{max}	<ul style="list-style-type: none"> - Plug-in jumpers SW1 and SW3 on the evaluation electronics FU 1-4 wrong
Mains module switches to failure during braking	<ul style="list-style-type: none"> - Braking energy too high
Mains module switches immediately to failure when being switched on	<ul style="list-style-type: none"> - Under-voltage - Over-voltage

7 Faults

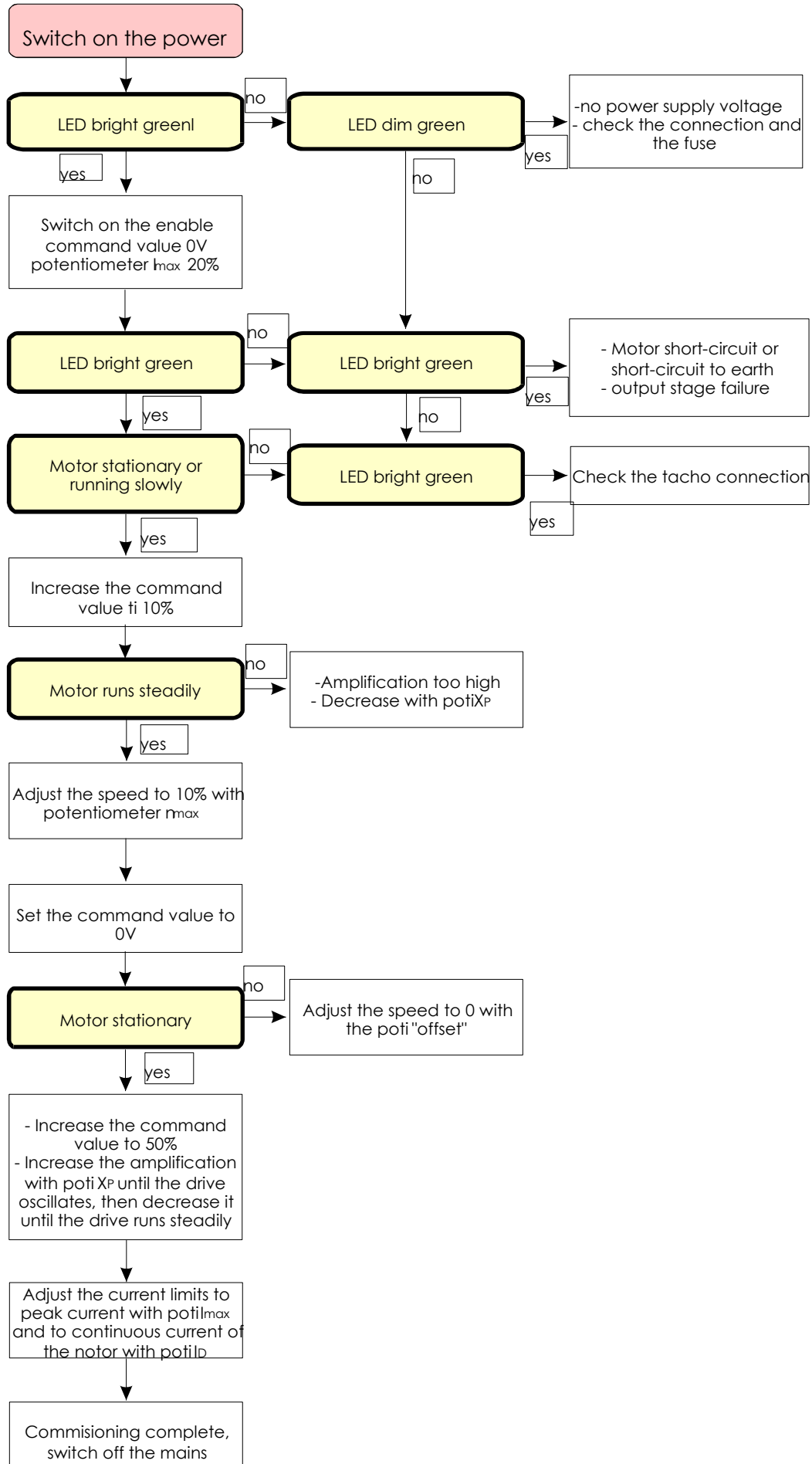

Signalplan TV3.2

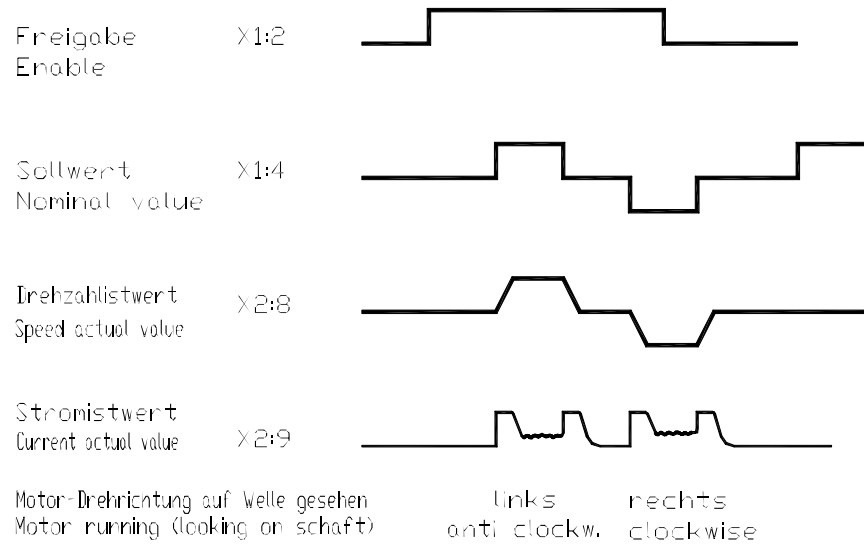

8 Protocol

Customer **Machine no.**
Device **Serial no.**

Connection voltage [V=,V~]

Inputs

Enable Contact ? Voltage [V=]
 Command value Type Voltage [V=]
 Current com. value I_{max1} external Voltage [V=]

Actual value settings - evaluation

DC tacho R23 Value[k \ast]
 IN-Evaluation Jumper SW1, 1-2/2-3 Position
 RS-Evaluation Switch RS-S1 ON/OFF K1 K1

Speed control loop settings

Variable components
 P-Component R9 Value
 I-Component C4 Value

Potentiometer settings

Speed n_{max} P2 Position
 Peak current I_{max} P5 Position
 Continuous current I_D P4 Position
 Amplification X_P P3 Position
 Offset Offset P1 Position

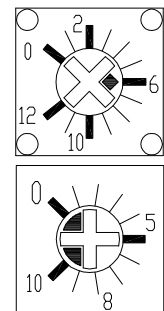

Current controller settings P/PI Switch S1, contact 1 ON/OFF

Measured data

Motor voltage max.
 Motor current peak continuous

Motor Data

Manufacturer Type
 Serial number
 Encoder type IMP Voltage
 Motor voltage Motor current
 Brake Fan

Guarantee

We guarantee that the device is free from material and production defects. Test results are recorded and archived with the serial number.

The guarantee time begins from the time the device is shipped, and lasts one year. WE undertakes no guarantee for devices which have been modified for special applications.

During the warranty period, we will, at its option, either repair or replace products that prove to be defective, this includes guaranteed functional attributes. We specifically disclaim the implied warranties or merchantability and fitness for a particular purpose. For warranty service or repair, this product must be returned to a service facility designated by us.

For products returned to us for warranty service, the Buyer shall prepay shipping charges to us and we shall pay shipping charges to return the product to the Buyer.

However, the Buyer shall pay all shipping charges, duties, and taxes for products returned to us from another country.

The foregoing warranty shall not apply to defects resulting from:

- * improper or inadequate repairs effected by the Buyer or a third party,
- * non-observance of the manual which is included in all consignments,
- * non-observance of the electrical standards and regulations
- * improper maintenance
- * acts of nature

All further claims on transformation, diminution, and replacement of any kind of damage, especially damage, which does not affect our device, cannot be considered. Follow-on damage within the machine or system, which may arise due to malfunction or defect in the device cannot be claimed.

This limitation does not affect the product liability laws as applied in the place of manufacture (i. e. Germany).

We reserve the right to change any information included in this MANUAL.

All connection circuitry described is meant for general information purposes and is not mandatory.

The local legal regulations, and those of the Standards Authorities have to be adhered to. We do not assume any liability, expressively or inherently, for the information contained in this MANUAL, for the functioning of the device or its suitability for any specific application.

All rights are reserved.

Copying, modifying and translations lie outside our liability and thus are not prohibited. Our products are not authorised for use as critical components in the life support devices or systems without express written approval.

The onus is on the reader to verify that the information here is current.